

# Geeetech A10 3D Printer

## User Manual (V2.0)

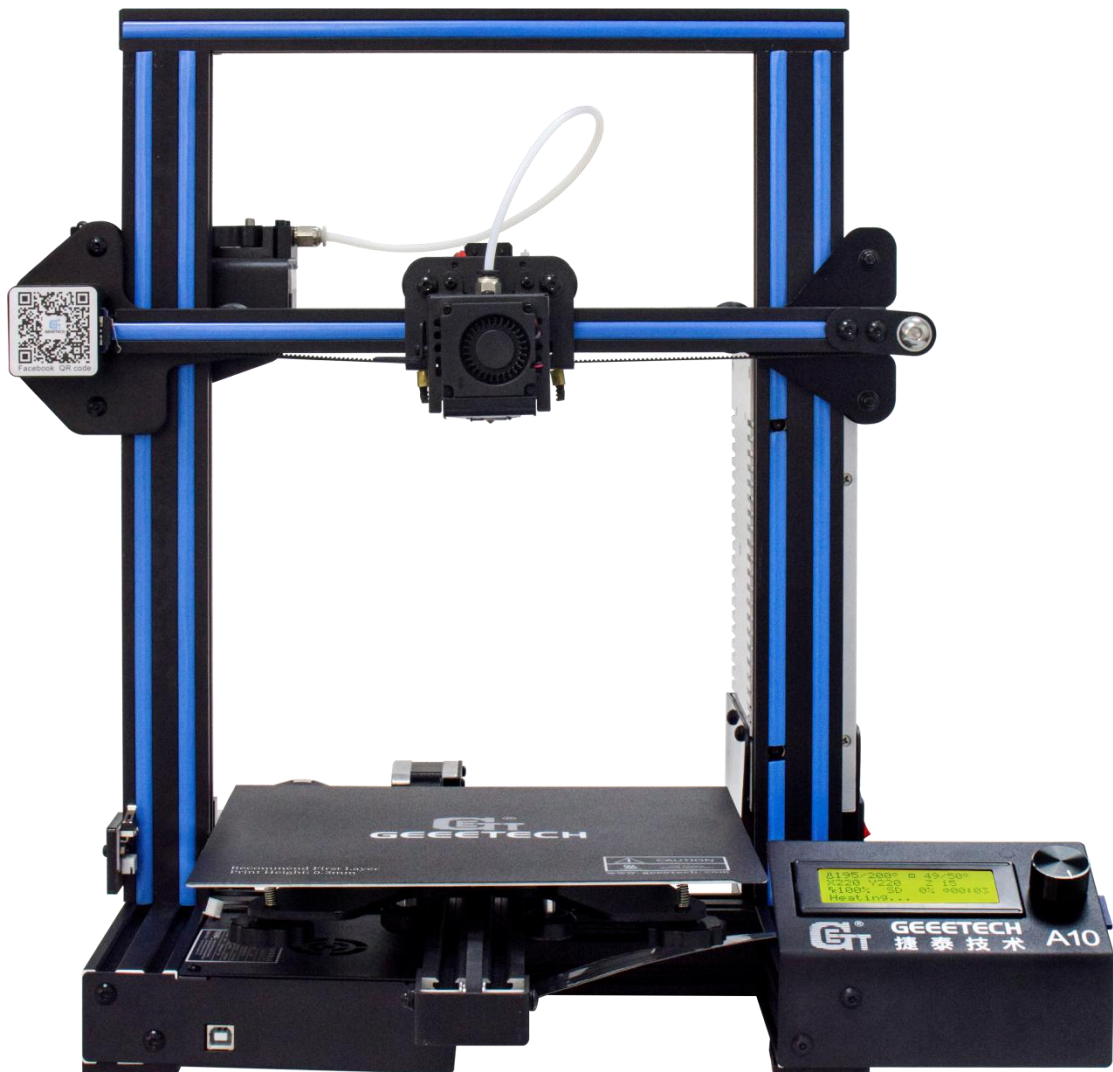

## Content

1 Attention .....	3
1.1 Safety instruction .....	3
1.2 Factory test before delivery .....	3
2 Printer display .....	4
3 Assembling .....	8
3.1 Assembling the main frame .....	8
3.2 Wire connection .....	11
3.3 Check the power input mode .....	14
3.4 Check the filament .....	14
4 First print .....	16
4.1 Level the print platform .....	16
4.2 SD card printing .....	18
5 Introduction to the LCD menu .....	21
5.1 Tree diagram .....	21
5.2 Main functions .....	22
6 Software setting .....	26
6.1 Install drive .....	26
6.2 Install slicing software .....	28
6.3 USB printing .....	39
6.4 SD card printing .....	43
7 Function introduction .....	45
7.1 Break-resuming capability .....	45
7.2 Reset button .....	45
7.3 Filament run-out sensor (Optional) .....	46
7.4 3D touch for auto bed leveling (Optional) .....	47
8 Parameters .....	47
9 Contact .....	48
10 FAQ (Frequently Asked Questions) .....	49
10.1 Abnormal extrusion .....	49
10.2 The gear of the extruder skips and makes an abnormal noise .....	49
10.3 First layer abnormal .....	49
10.4 Layer shift .....	49
10.5 Print stopped .....	50
11 Declaration .....	50
11.1 Terms .....	50
11.2 Disclaimers .....	50

## 1 Attention

### 1.1 Safety instruction

- 1) Please switch to the correct local voltage (115V-230V) before turning on the printer. Be sure the switch is in the correct position or it would cause damage to the power supply unit (PSU).

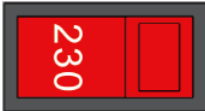

- 2) Be sure all wires are correctly connected before turning on the printer.
- 3) Don't touch the extruder head and hot bed when the printer is working as they generate high temperature which may cause burn.
- 4) Don't leave the printer alone when it is working.

### 1.2 Factory test before delivery

In order to ensure the quality, each printer will be tested in the factory before delivery. As a result, there may be a little residue in the extruder head or on the hot bed, but it won't affect the normal use. And we provide the spare nozzle in the accessory kit. Thanks for your understand.

## 2 Printer display

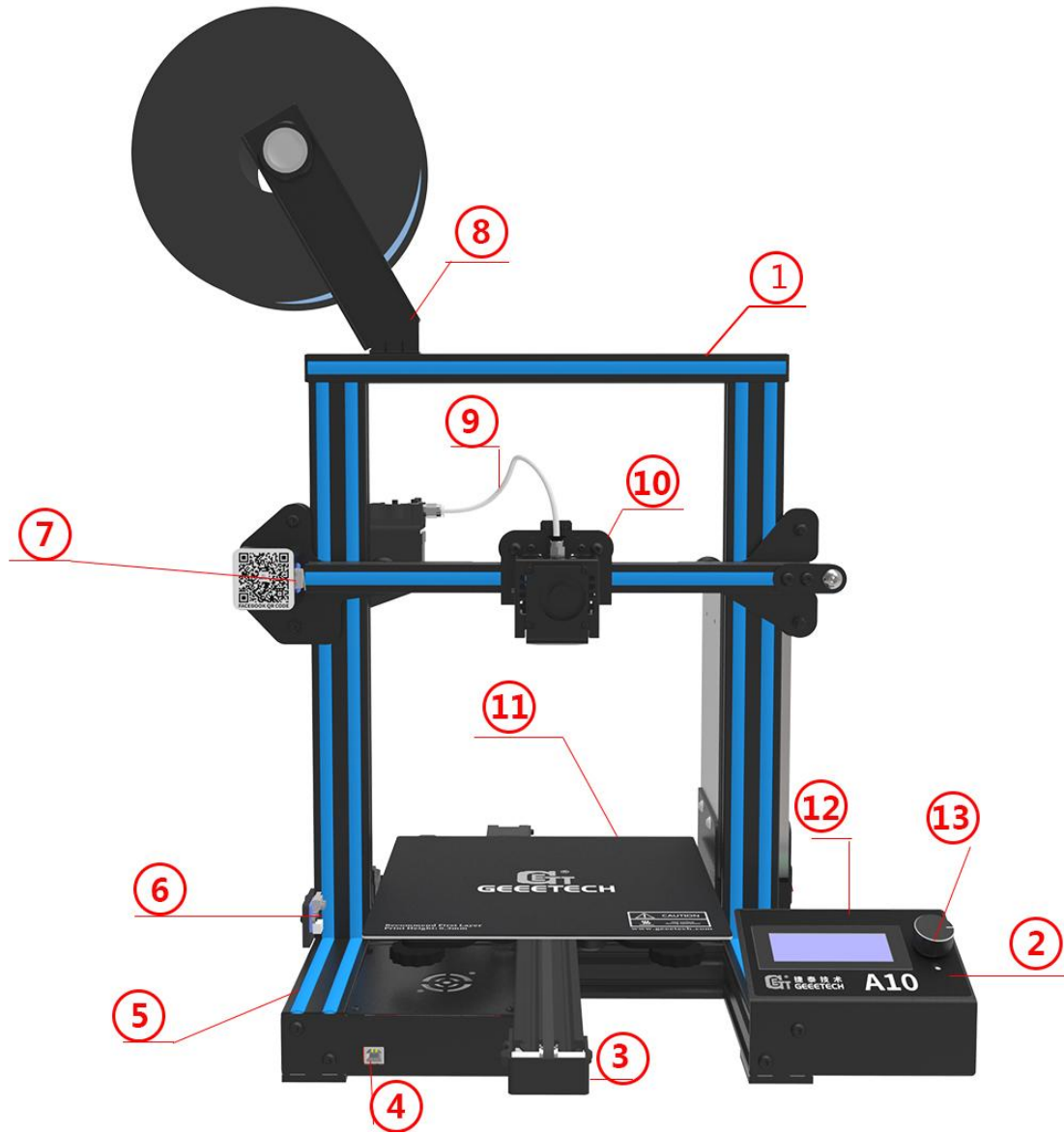

(Picture 2-1)

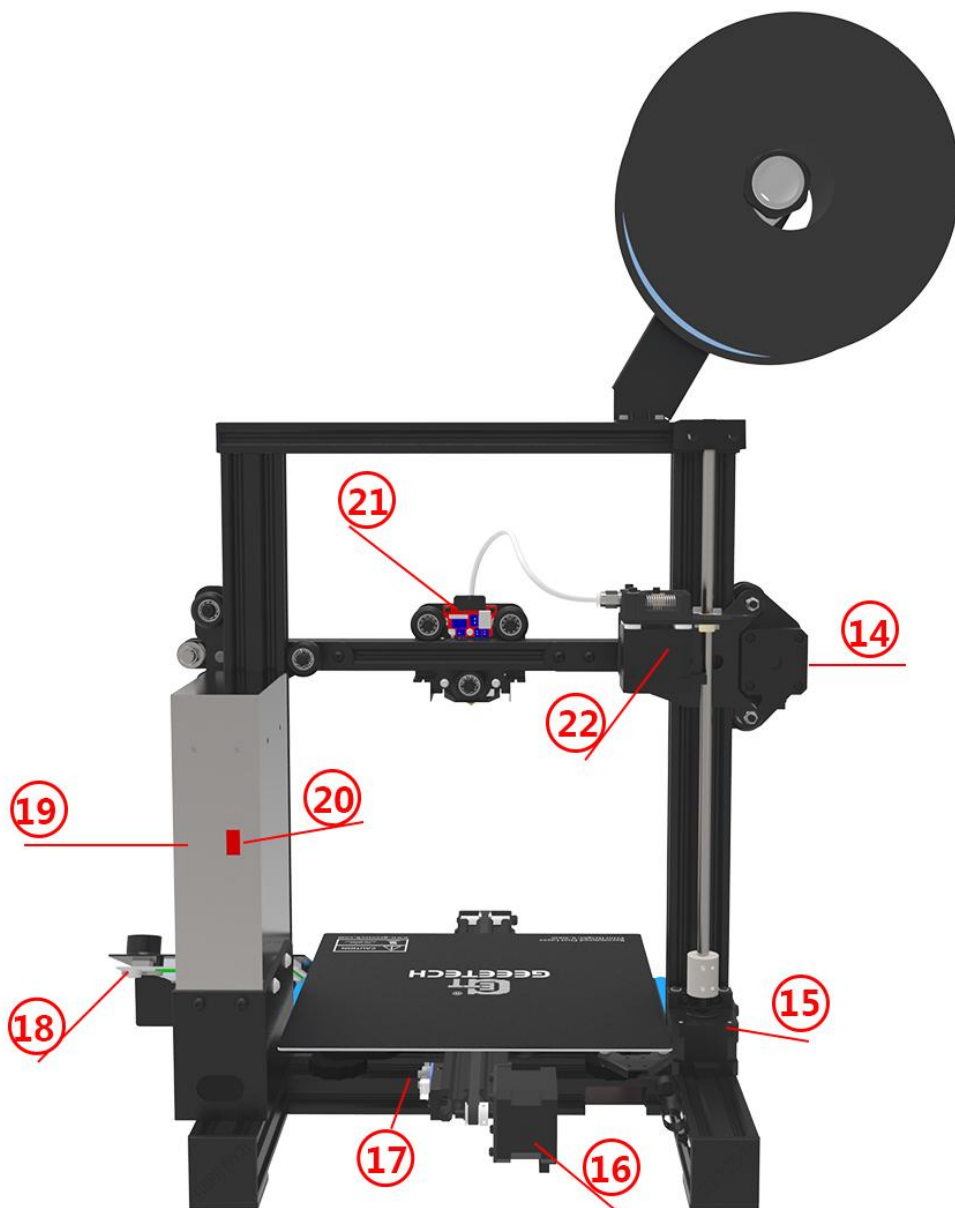

(Picture 2-2)



(Picture 2-3)

1. Gantry frame
2. Reset button
3. Y axis
4. USB port
5. Pedestal
6. Z axis end stop
7. X axis end stop
8. Filament spool holder kit
9. Teflon tube
10. Extruder head kit
11. Hot bed
12. LCD2004 screen
13. Knob
14. X axis motor
15. Z axis motor
16. Y axis motor
17. Y axis end stop
18. SD card slot

- 19. PSU kit
- 20. PSU switch
- 21. Extruder wire connector
- 22. Extruder kit
- 23. Power switch

Please check the accessories first when you've received the printer (Refer to picture 2-4). If missing any spare part, please contact your sales timely.



(Picture 2-4)

### 3 Assembling

#### 3.1 Assembling the main frame

The main frame consists of the gantry frame and the pedestal, PSU kit, LCD kit, spool holder kit, and their supporting screws. See picture (3-1).

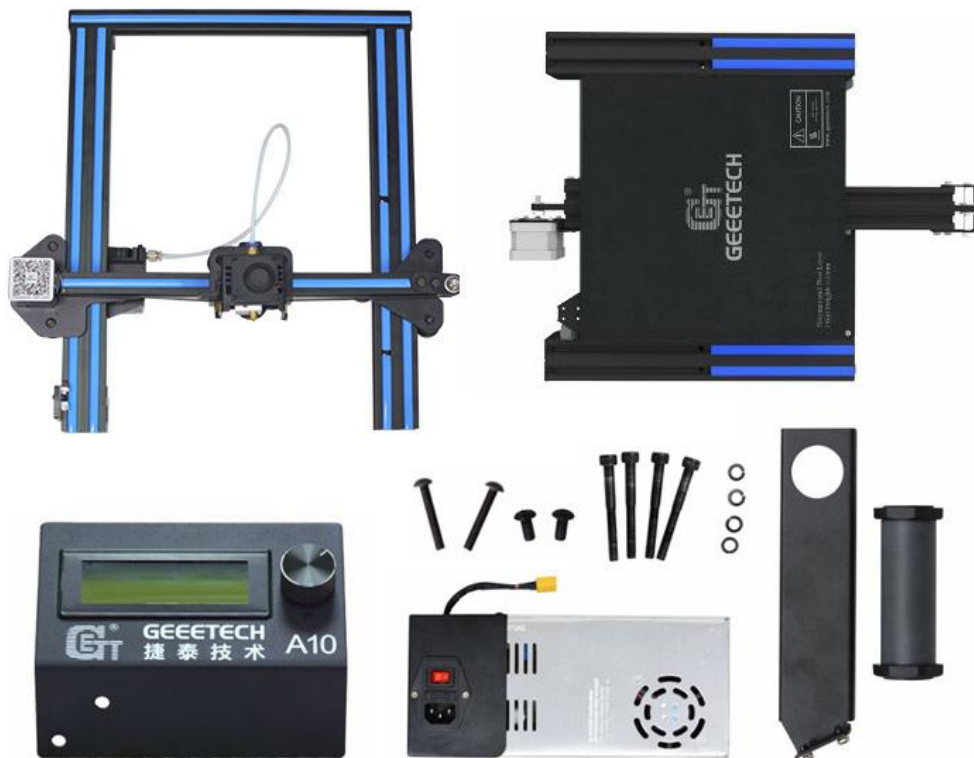

(Picture 3-1)

- 1) Assemble the gantry frame and pedestal from bottom to top with 4 M5x45 screws and 4 M5 spring washers. See picture (3-2).

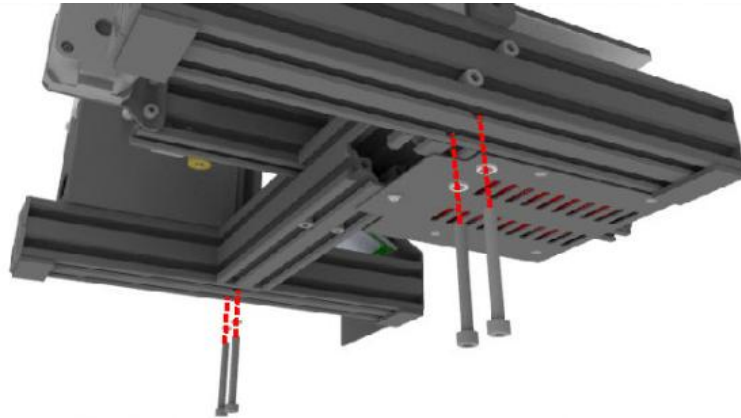

(Picture 3-2)

- 2) Fix the PSU kit to the gantry frame with 2 M4x20 screws. See picture (3-3).

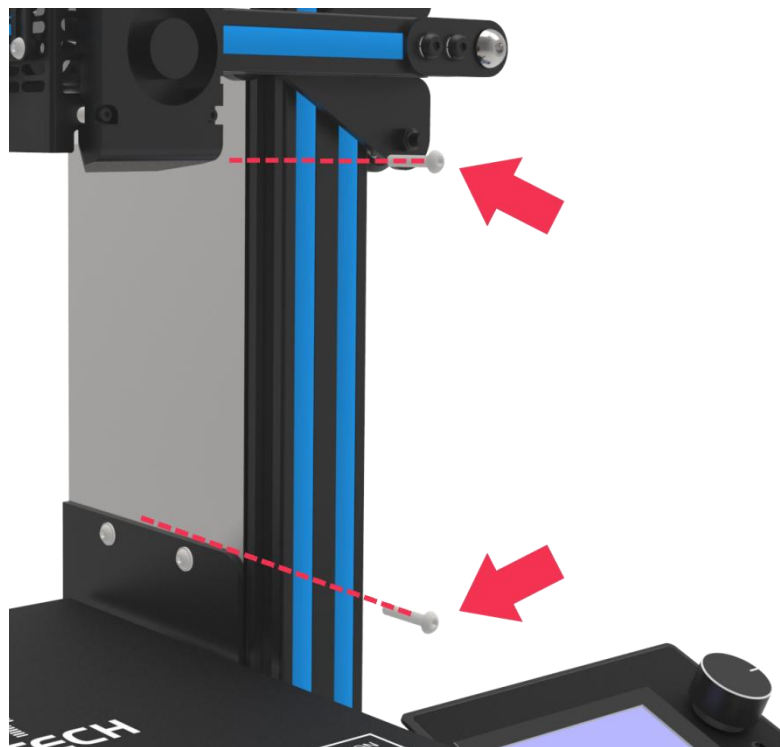

(Picture 3-3)

- 3) Fix the LCD kit to the correct holes on the right side of the pedestal with 2 M5x10 screws. See picture (3-4).

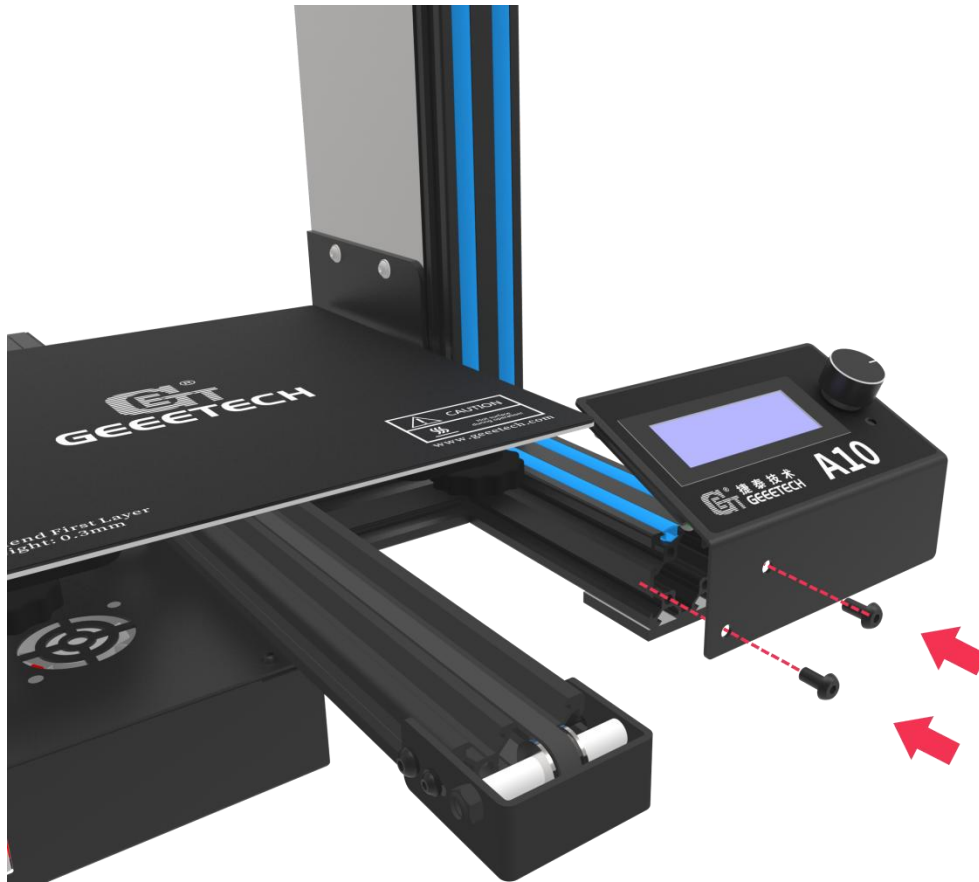

(Picture3-4)

- 4) Fix the spool holder to the top gantry with 2 M3x6 and 2 M3 T-shape nuts. Details see picture (3-5).

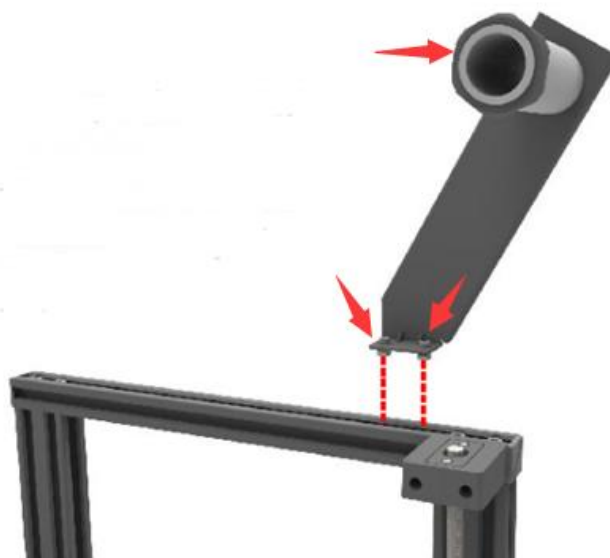

(Picture 3-5)

### 3.2 Wire connection

- 1) The teflon tube is connected to the quick-insert connector of the extruder and the extruder head. **Be sure the Teflon is inserted into the very bottom or it may cause clog.** Details see picture (3-6, 3-7).



(Picture 3-6)



(Picture 3-7)

- 2) Insert the flat ribbon of the LCD into the socket behind the LCD screen. See picture (3-8)



(Picture 3-8)

- 3) Connect the PSU cable. See picture (3-9)

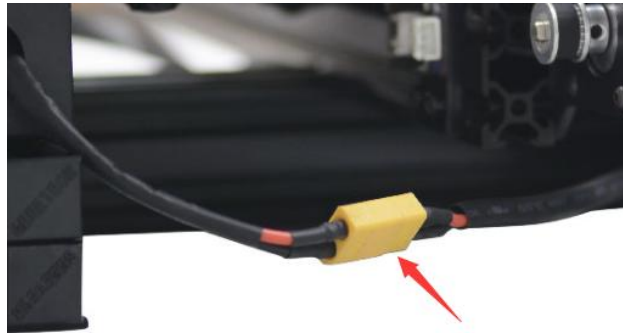

(Picture 3-9)

- 4) Plug the extruder cables into the socket of the extruder head extension board as firmly as possible. See picture (3-10)

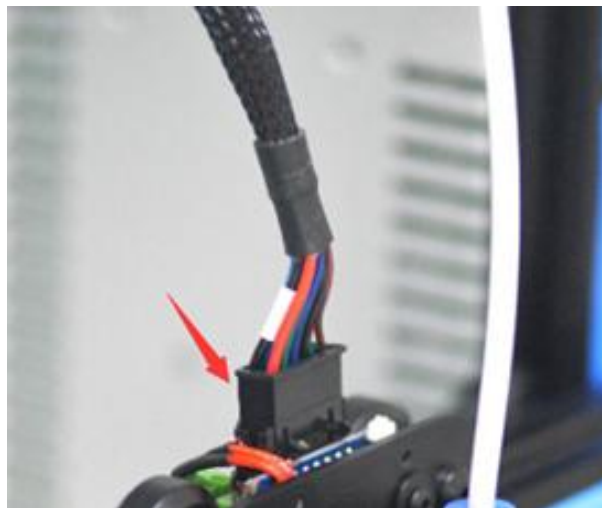

(Picture 3-10)

- 5) Connect the extruder motor wires. See picture (3-11).

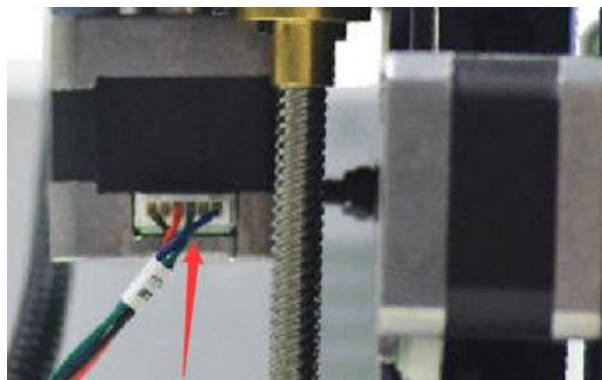

(Picture 3-11)

- 6) Connect the wires of X axis' motor and end stop. See picture (3-12).

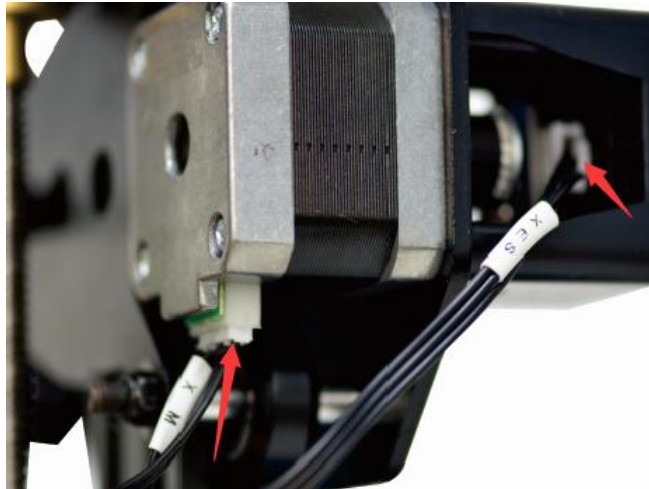

(Picture 3-12)

- 7) Connect the wires of Y axis' motor and end stop. See picture (3-13).

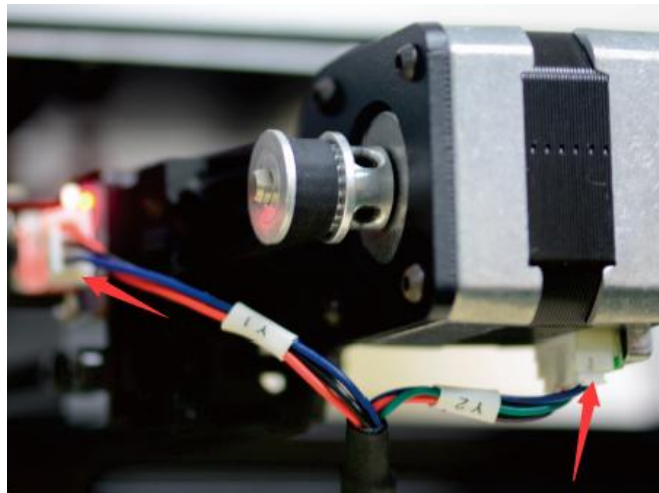

(Picture 3-13)

- 8) Connect the wires of Z axis' motor and end stop. See picture (3-14, 3-15).

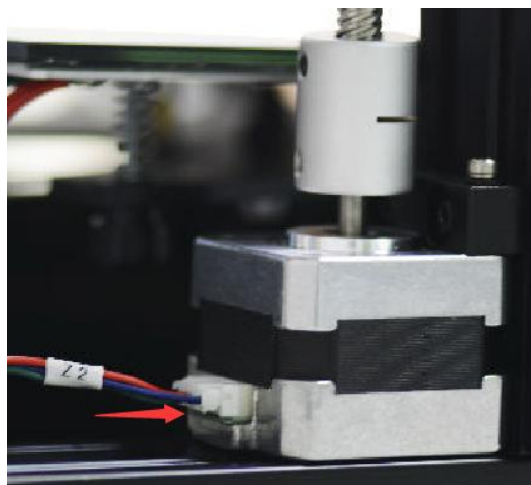

(Picture 3-14)

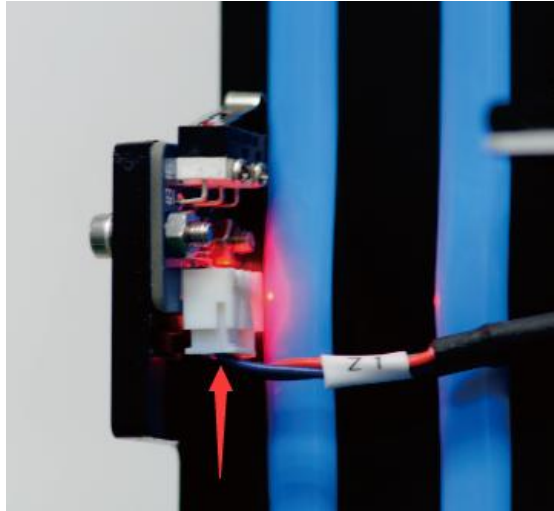

(Picture 3-15)

### 3.3 Check the power input mode.

Choose the correct voltage according to your local standard requirement. See picture (3-16)

**(Be sure the voltage is switched to the correct one. We provide 230V and 115V for option.)**

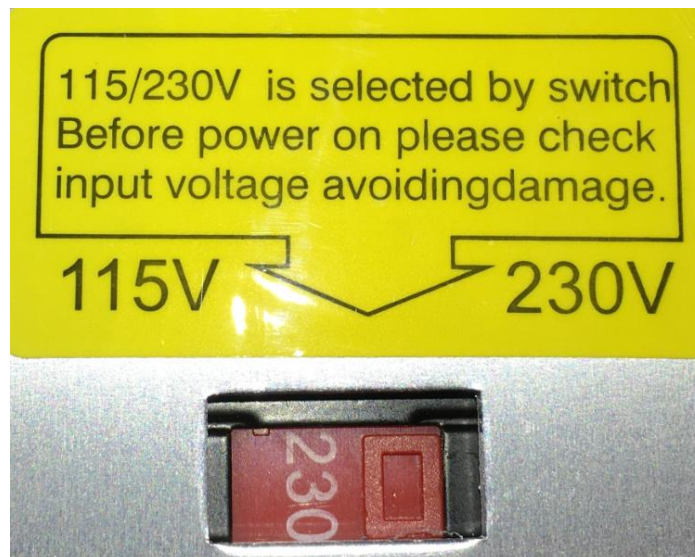

(Picture 3-16)

### 3.4 Check the filament

Put the filament on the spool holder. Please pay attention to the feeding direction of the filament. See picture (3-17).

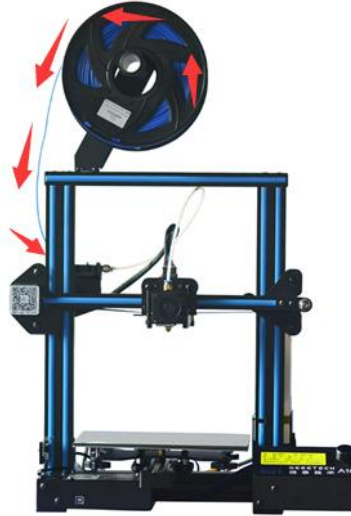

(Picture 3-17)

Since the filament is bent, the first section of it needs to be straightened by hand and sharpened with scissors to make it easier to insert the filament into the bottom of the extrusion head. Press down the lever handle of the extruder and insert the filament into the feeding tube until it reaches the extruder head. See picture (3-18).



(Picture 3-18)

When print PLA, set the target nozzle temperature about 180-210°C. When the temp is stable, control the extruder filament feeding on LCD screen (“Move axis”), extruder will automatically feed until there is molten material flowing from the nozzle.

Observe the nozzle, if there is no obvious stuck and the filament is out smoothly, then stop filament feeding, clear the nozzle with tweezers. See picture (3-19).

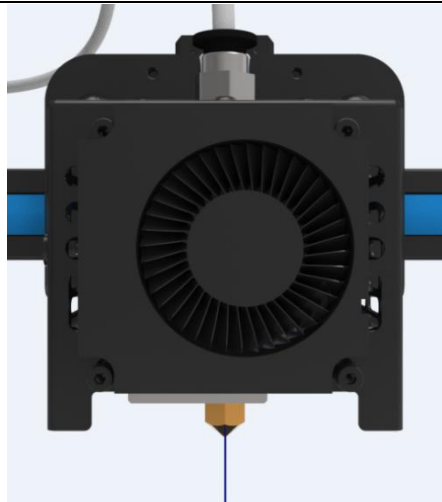

(Picture 3-19)

## 4 First print

### 4.1 Level the print platform

The first layer is the key to the quality of the print model. The factory default setting is a little high in order to avoid scratching the hotbed and nozzle, so users need to adjust the distance between nozzle and hotbed again. After the first-time bed leveling finished, users don't need to level the bed in future printing.

#### 1) Rough leveling

Home the printer first (Prepare> Auto home), then it shows the option "Level corners" on the LCD screen. Put a piece of A4 paper on the platform, click "Next corner", the extruder head moves counterclockwise from the bottom left corner to the four corners of the platform. See picture (4-1).

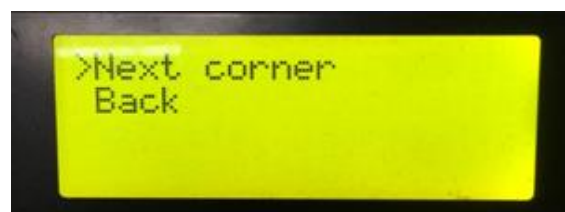

(Picture 4-1)

When the extruder head moves to the left bottom, adjust the corresponding nut until the distance between the nozzle and bed is about the thickness of a piece of paper (about 0.1-0.2mm). Twitch the paper back and forth to see if you feel any slight resistance. If yes, it means the leveling of this corner is finished and you can proceed to level the rest corners with the same method. See picture (4-2).



(Picture 4-2)

2) Accurate leveling

If only level the bed with A4 paper, the first layer maybe too high, too low or moderate.

a. Too high: the distance between the nozzle and bed is too far, which may cause the filament won't stick or can't stick firmly. See picture (4-3).

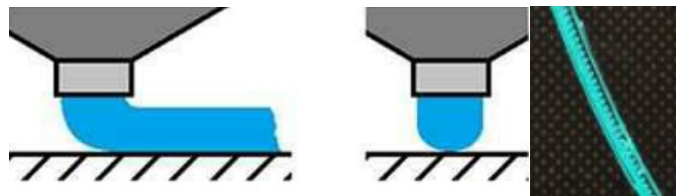

(Picture 4-3)

b. Too low: the distance between the nozzle and the bed is too close, which prevents the filament from running out and causes the extruder gear to click, and even worse, scratches the nozzle and the bed. See picture (4-4).

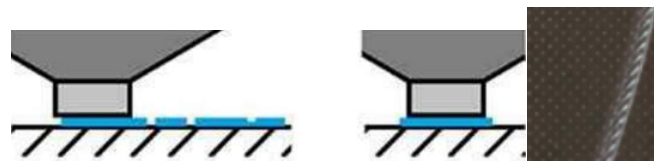

(Picture 4-4)

c. Moderate: Extrude the filament properly and evenly stick on the bed. See picture (4-5).

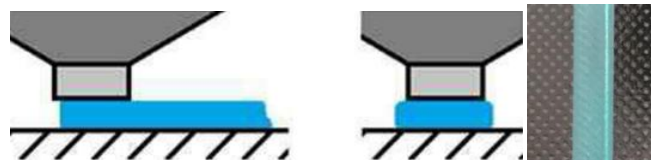

(Picture 4-5)

In the case of too low and too high, adjust the nuts under the platform till they are moderate. It may take time and energy to achieve the best result.

An example of good first layer, see picture (4-6).

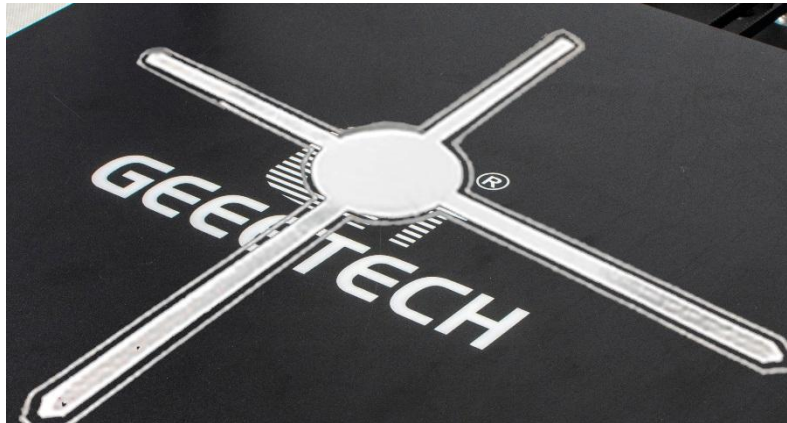

(Picture 4-6)

**Note:**

- 1) If turn the nuts clockwise, the platform will rise, and vice versa.
- 2) Avoid the nozzle touching the bed; put a piece of A4 paper instead. Or it will scratch the bed.

For more details, please refer to this link:

<http://geeetech.com/forum/viewtopic.php?f=112&t=62296>

## 4.2 SD card printing

Insert the SD card into the slot. See picture (4-7)



(Picture 4-7)

Press and rotate the knob to enter the main menu. Select the option of "Print from SD". See picture (4-8).



(Picture 4-8)

Choose the files in the SD card. See picture (4-9).

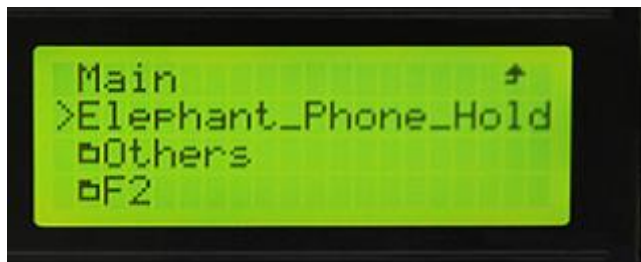

(Picture 4-9)

The printer will heat automatically. See picture (4-10).



(Picture 4-10)

When heating done, the printer will start printing. See picture (4-11, 4-12).



(Picture 4-11)

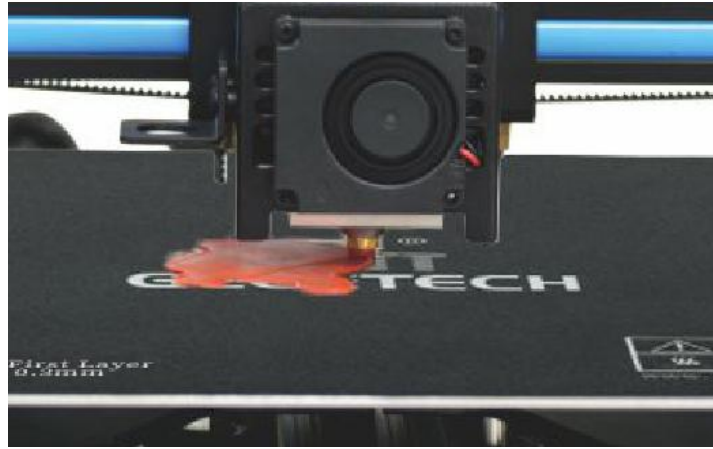

(Picture 4-12)

## 5 Introduction to the LCD menu

### 5.1 Tree diagram

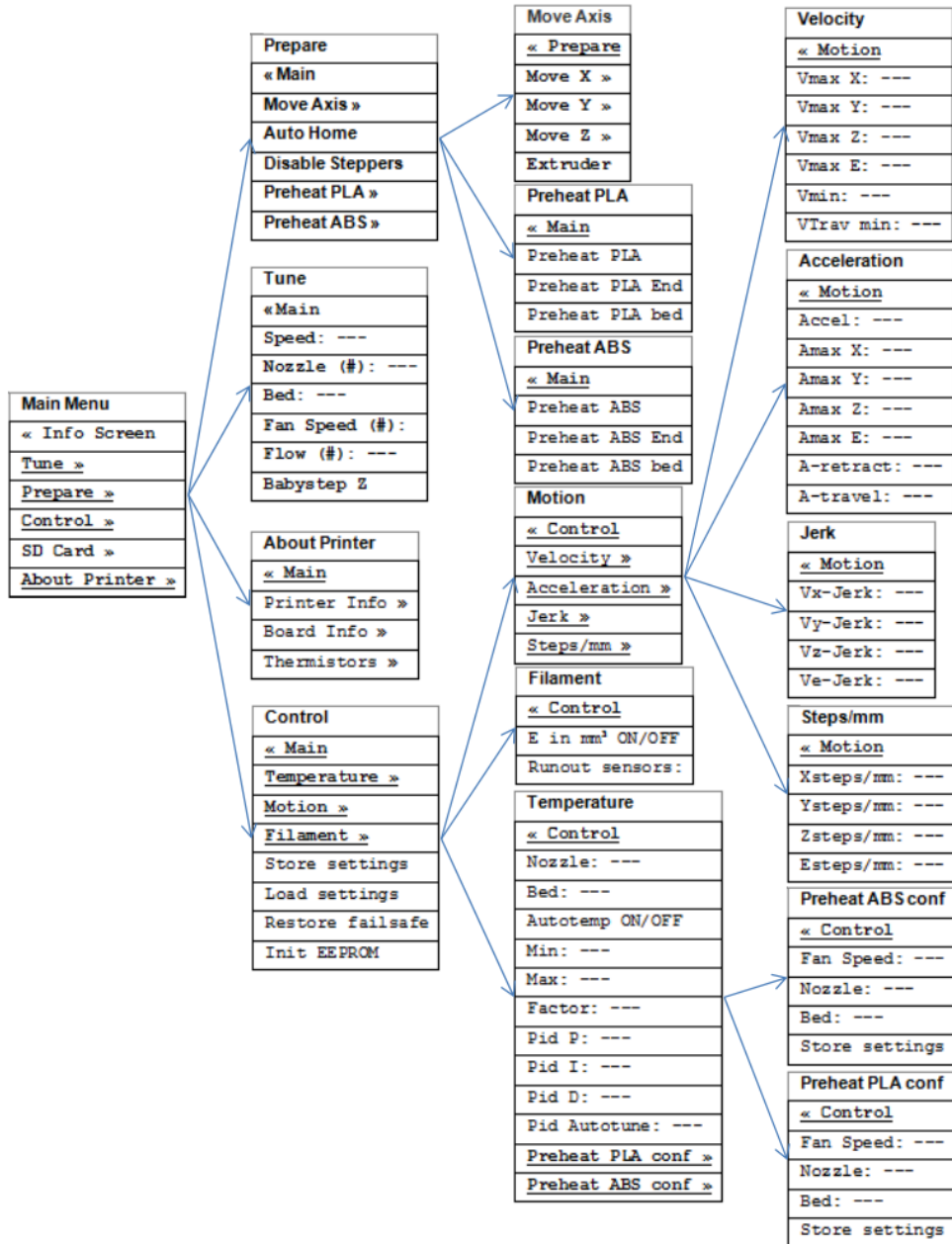

(Picture 5-1)

## 5.2 Main functions

### LCD rotating knob:

- 1) Press the knob: Confirm or enter the next menu.
- 2) Rotate the knob: Roll the select options or change parameters.

### LCD homepage (Picture 5-2):

- ① Extruder temperature: Current temp/target temp
- ② Hot bed temperature: Current temp/target temp
- ③ Current X/Y/Z axis value
- ④ Feed rate: Current printing speed
- ⑤ Current printing process



(Picture 5-2)

**Note:** Rotating the knob can change the printing feed rate during printing. We suggest users not changing the feed rate too much or it will cause the motors to step out and affect the print quality.

### Press the knob to enter the next menu (Picture 5-3):

1. Prepare: Prepare and test the printer before normal operation
2. Control: Printer temp and motion parameter setting
3. SD card status

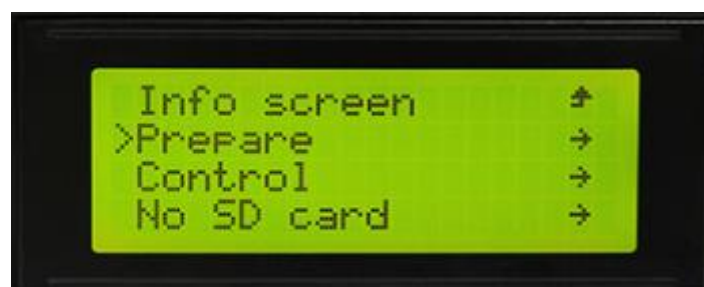

(Picture 5-3)

**The main functions of Prepare menu (Picture 5-4, 5-5, 5-6):**

1. Disable steppers: Unlock motors
2. Auto home: Auto home of X/Y/Z axis
3. Preheat PLA: Manually pre-heat the hot bed and extruder before printing PLA.
4. Preheat ABS: Manually pre-heat the hot bed and extruder before printing ABS.
5. Move axis: Move X/Y/Z axis and extruder



(Picture 5-4)



(Picture 5-5)



(Picture 5-6)

**The main functions of Control menu (Picture 5-7):**

1. Temperature: Change the temp of the hot bed and extruder in real time during printing. Customize the temp of preheat PLA and preheat ABS.
2. Motion: Motion parameter setting in firmware. After modification, choose “store memory” to save the change.
3. Store memory: Save the change made.

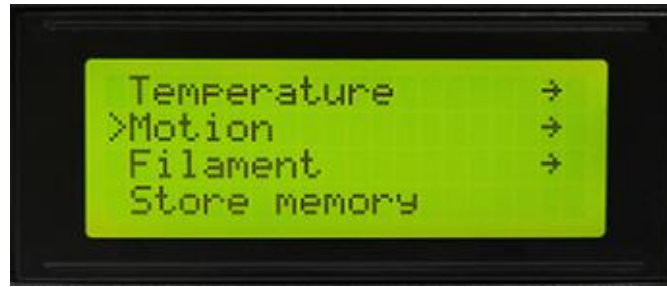

(Picture 5-7)

After getting familiar with the LCD function, press the knob on the LCD to enter the next level menu and select "Prepare". See picture (5-8)



(Picture 5-8)

Choose "Auto home" to home the printer, see picture (5-9).



(Picture 5-9)

Choose "Move axis" to move motors. See picture (5-10)



(Picture 5-10)

Choose "Move 1mm", see picture (5-11)



(Picture 5-11)

**Note:** Only the two options 10mm and 1mm are valid for extruder. 0.1mm is invalid. We suggest choosing 1mm for each axis to test.

Choose the corresponding axis you want to move “MoveX/Y/Z/Extruder”. Rotate the knob to make the axis move. See picture (5-12).



(Picture 5-12)

After axis’s testing finished, if you want to unlock the motor, choose “Prepare>Disable steppers”, see picture (5-13).



(Picture 5-13)

When the motors are unlocked, you can move them by hand.

## 6 Software setting

### 6.1 Install drive

Two printing choices for A10: SD card printing and USB printing.

**SD card printing:** After leveling, insert the SD card into the slot, and choose a .gcode file to start printing.

**USB printing:** Connect the printer and computer with a USB cable and control the printer to work with slicing software such as Repetier-Host, Cura, Simplify3D, Slic3r, etc. Because of some unstable factors such as signal interference, the USB printing prone to fail. So we suggest choosing SD card printing.

The details of USB printing are as follows:

Firstly, turn on the printer, and connect the printer to computer with a USB cable. Normally, the computer will automatically search the install drive. The newest communication chip of A10 is CH340. See picture (6-1).

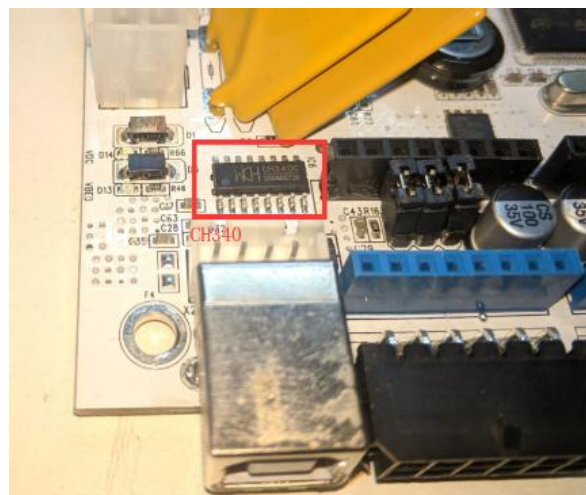

(Picture 6-1)

If it fails to automatically install the drive in computer, then check whether the drive is installed successfully or not. Click to choose “My computer>Property>Device manager”.

If it shows the exclamation mark as picture below (6-2), then you need manually install the drive in the computer.

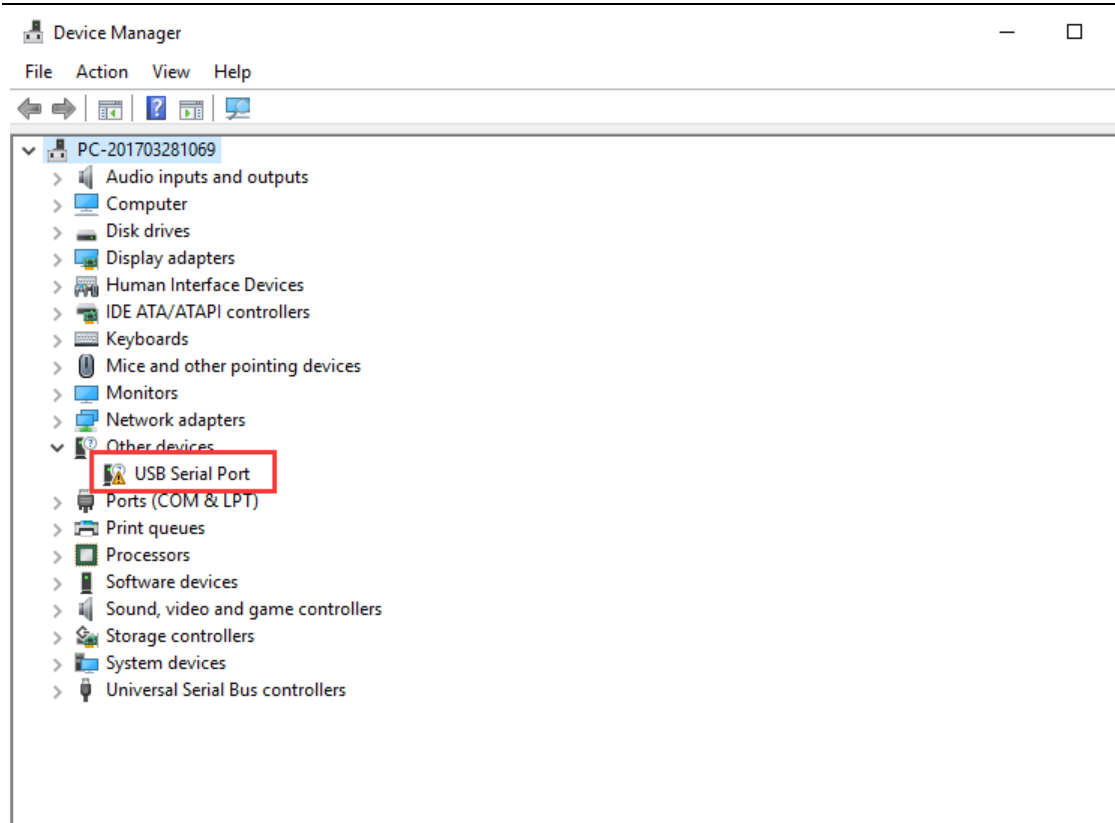

(Picture 6-2)

Download link for CH340:

[https://www.geeetech.com/index.php?main\\_page=download&download\\_id=30](https://www.geeetech.com/index.php?main_page=download&download_id=30)

After the drive installed, check the "Device manager" of yours and see if it is same as the picture below (6-3). If so, it means the drive is successfully installed.

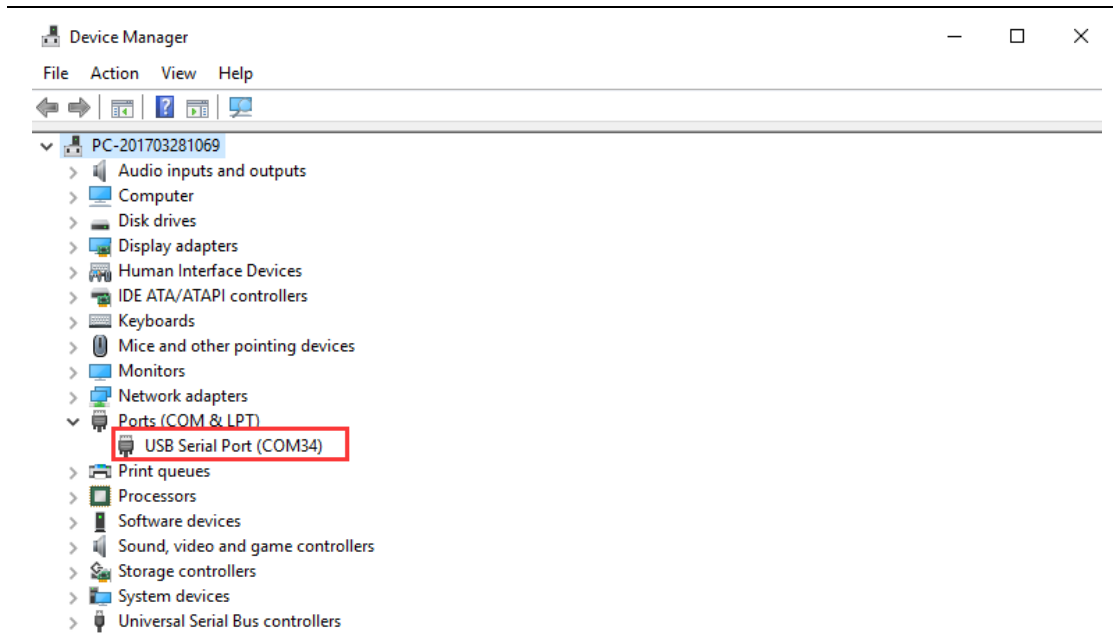

(Picture 6-3)

## 6.2 Install slicing software

Repetier-Host is the default slicing software here. Download address:

<https://www.repetier.com/download-software/>

### 1) Set printer parameters

When Repetier-Host is installed, turn on the printer and open the Repetier-Host. Repetier-Host supports several languages. You can choose your mother language from Config>Language (Picture 6-4 for details).

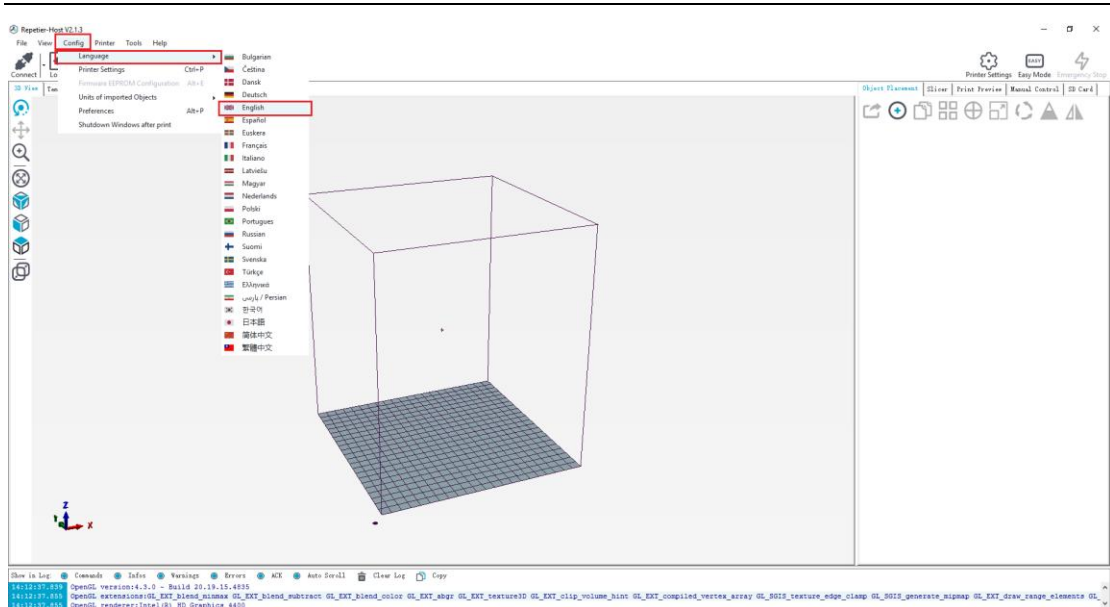

(Picture 6-4)

English interface for your reference (picture 6-5).

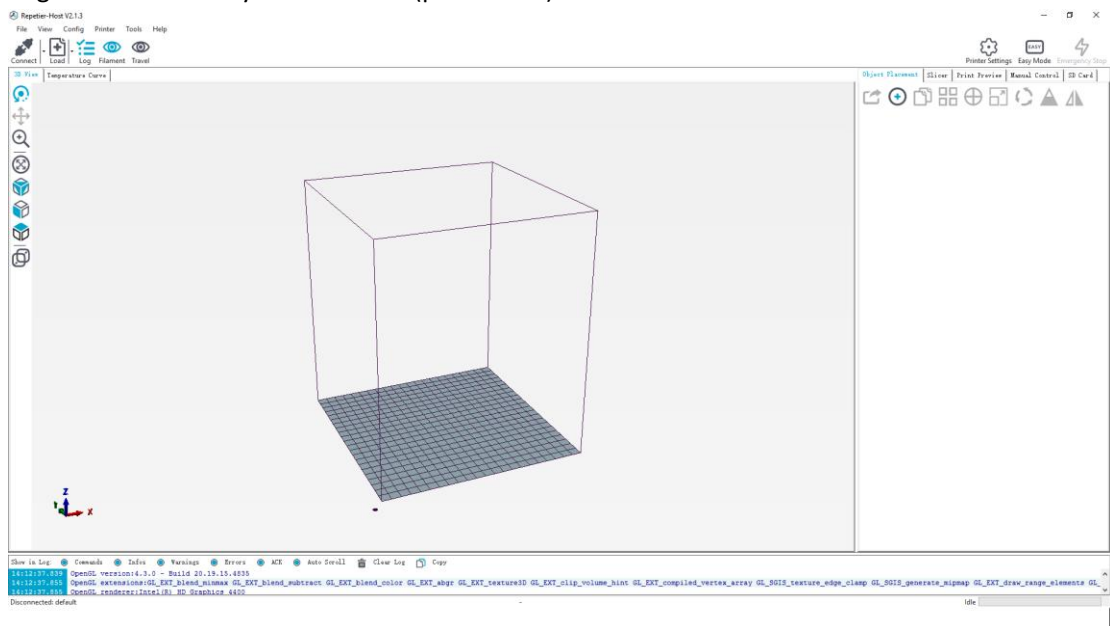

(Picture 6-5)

Using the Repetier-Host for the first time, printer parameters need to be configured before connecting.

Click “Printer settings” on the top right corner, see picture (6-6).

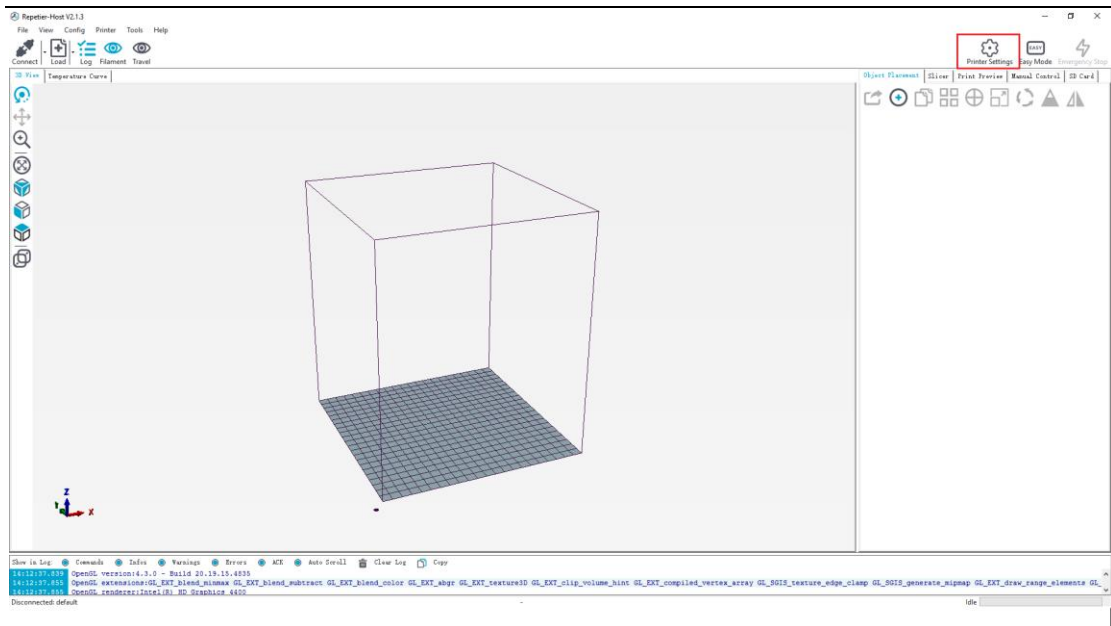

(Picture 6-6)

It pops up the content as the picture below (6-7). Write down the relevant info accordingly. (Pay attention to the highlighted parts)

a. Connection dialog:

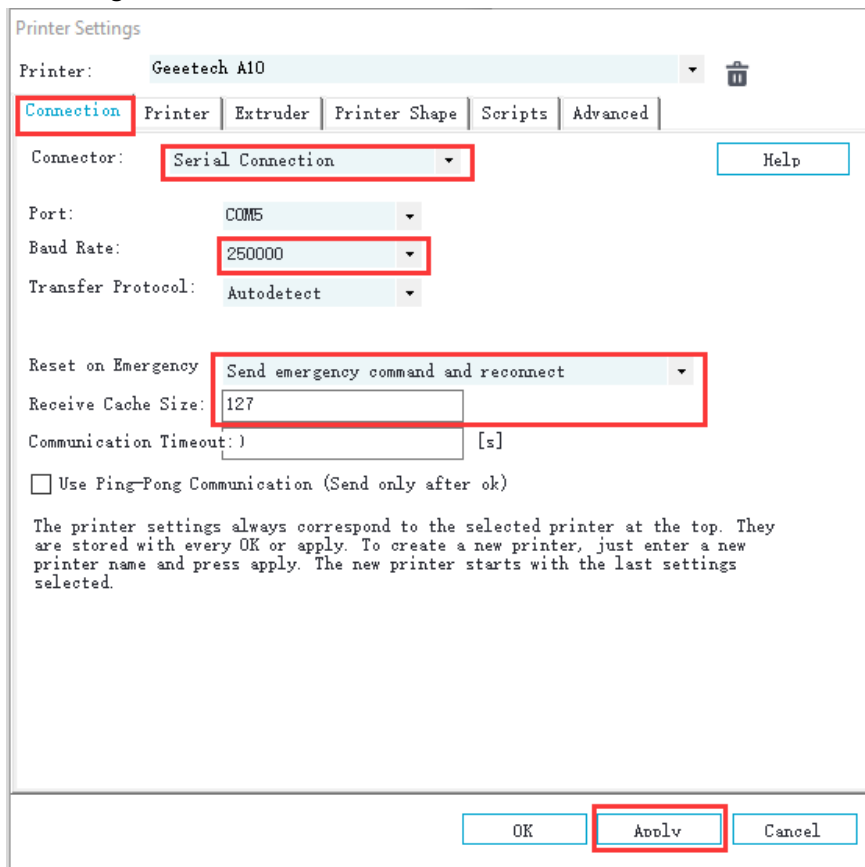

(Picture 6-7)

b. Printer dialog (Picture 6-8):

Printer Settings

Printer: Geeetech A10 🗑️

Connection
Printer
Extruder
Printer Shape
Scripts
Advanced

Firmware Type: Autodetect ▼

Travel Feed Rate: 4800 [mm/min]

Z-Axis Feed Rate: 100 [mm/min]

Manual Extrusion Speed: 2 20 [mm/s]

Manual Retraction Speed: 30 [mm/s]

Default Extruder Temperature: 200 °C

Default Heated Bed Temperature: 55 °C

Check Extruder & Bed Temperature

Remove temperature requests from Log

Check every 3 seconds.

Park Position: X: 0 Y: 0 Z min: 0 [mm]

Send ETA to printer display  Go to Park Position after Job/Kill

Disable Extruder after Job/Kill  Disable Heated Bed after Job/Kill

Disable Motors after Job/Kill  Printer has SD card

Add to comp. Printing Time 8 [%]

Invert Direction in Controls for X-Axis  Y-Axis  Z-Axis  Flip X and Y

OK
Apply
Cancel

(Picture 6-8)

c. Extruder dialog (Picture 6-9):

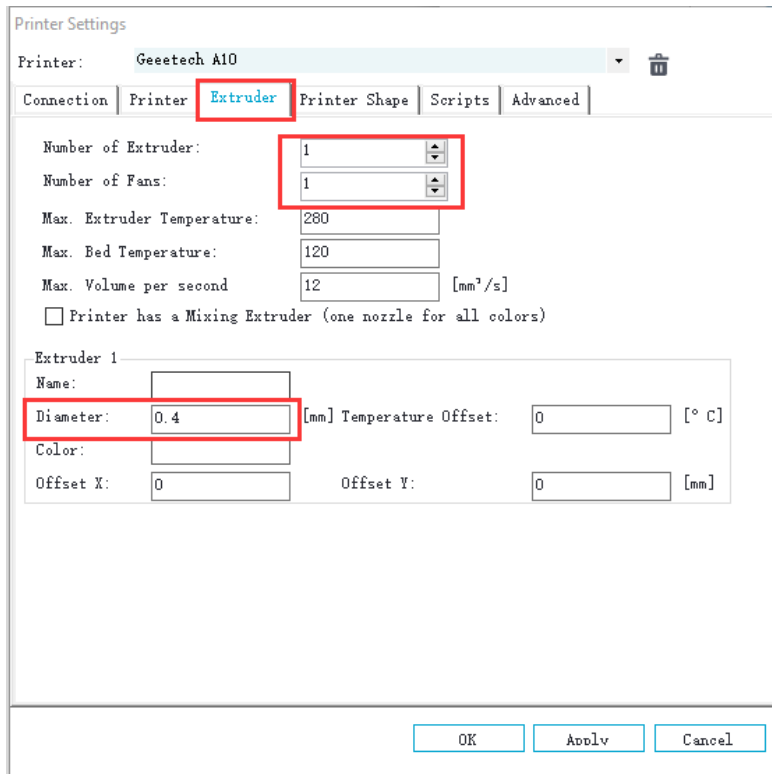

(Picture 6-9)

d. Printer shape dialog (Picture 6-10):

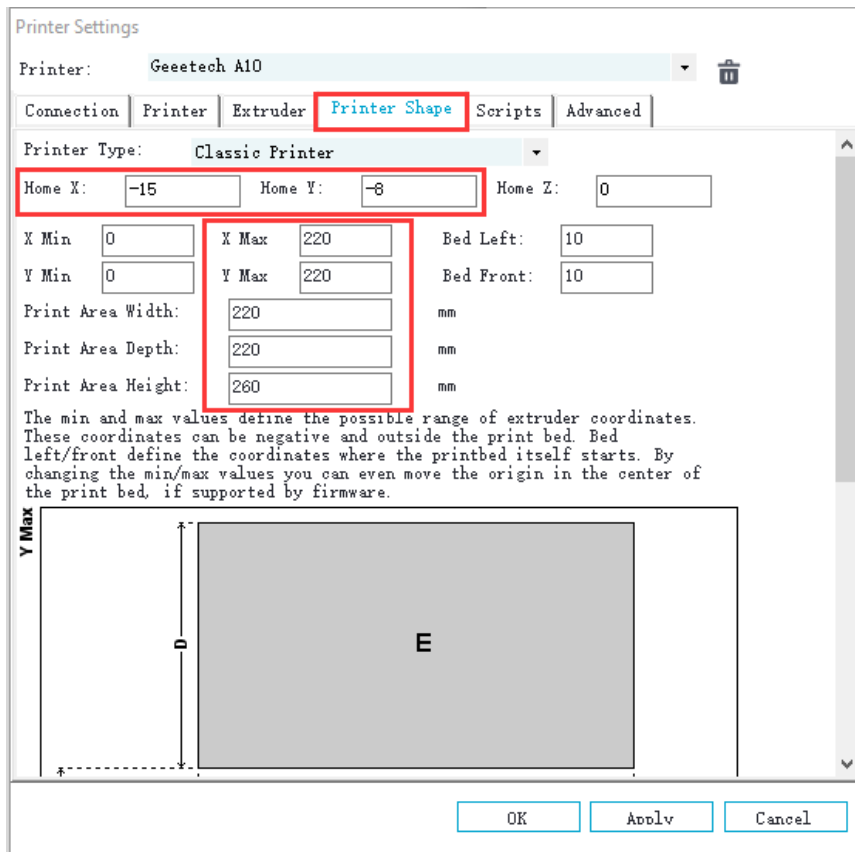

(Picture 6-20)

Now the printer parameters are set.

**Note:** If the operation system is Mac OS, the baud rate is still 250000.

1) Set slicing parameters

After setting the printer parameters, click “Connect” on the top left corner. The color of the icon changed to green means the printer connects to the Repetier-Host successfully. Click it again to disconnect. See picture (6-11).

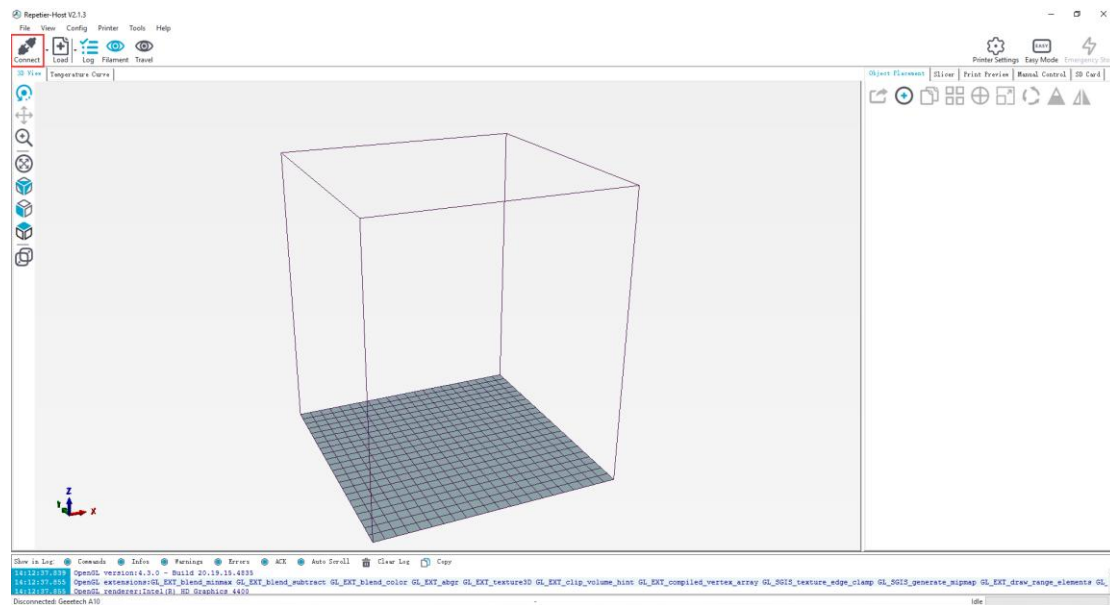

(Picture 6-11)

After successfully connected, choose “Slicer> CuraEngine” and open the configuration menu. See picture (6-12).

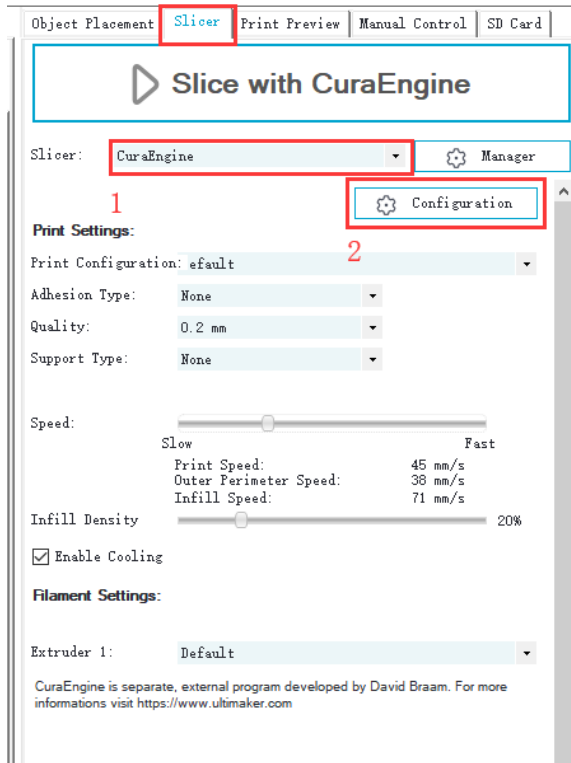

(Picture 6-12)

It pops up dialog as picture below (6-13):

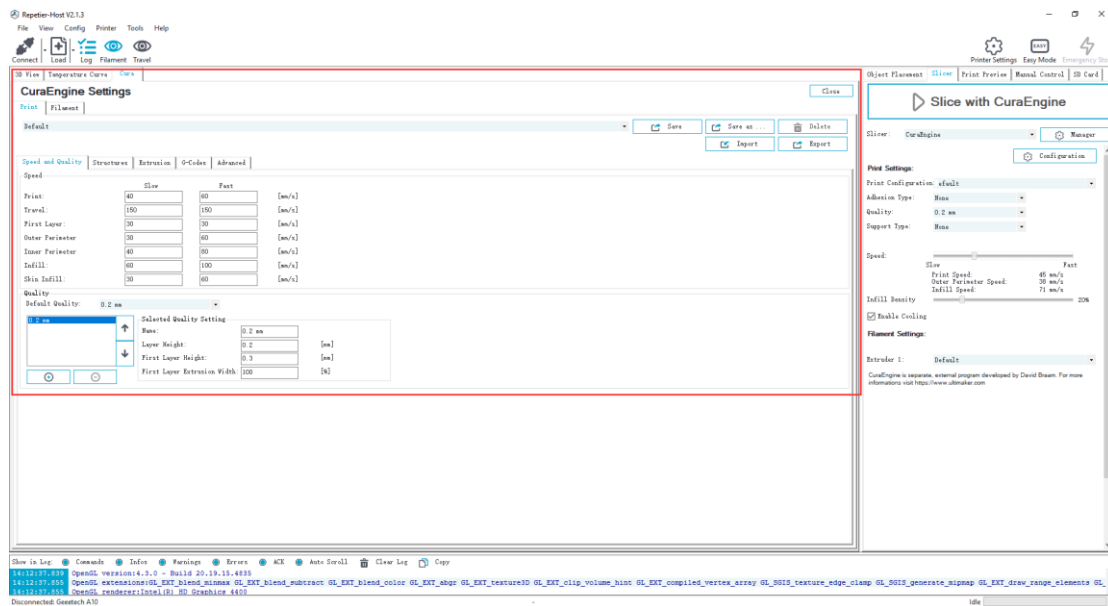

(Picture 6-13)

Printer parameters are important to print quality. Customers need to test to find out the best parameters for their printers.

Here we provide a configuration file for your reference (“Geeetech A10 PLA high.rcp”). You can import it according to the steps as follows.

The following is an example of parameters for PLA (Picture 6-14):

Click “Print>Import”

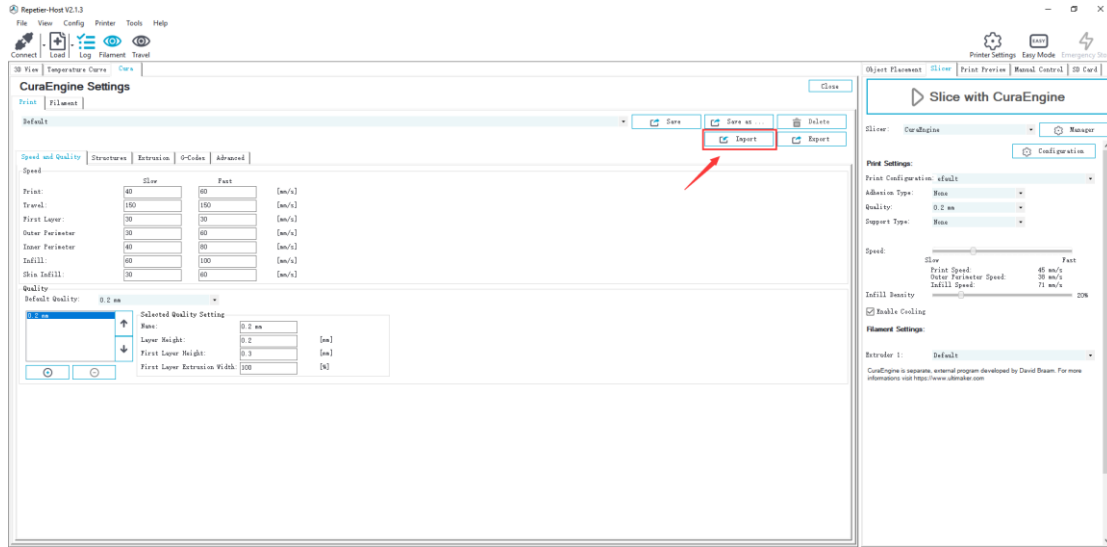

(Picture 6-14)

It pops up the dialog as below (Picture 6-15). Choose “Geeetech A10 PLA high.rcp” and open it.

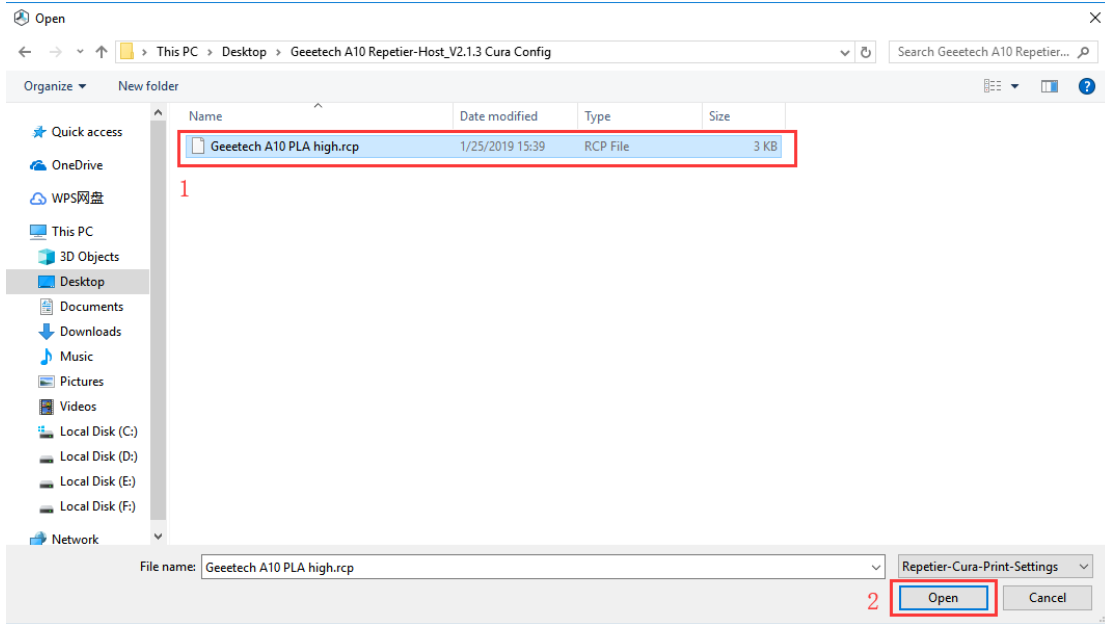

(Picture 6-15)

Now, the configuration file is imported, click “Save”. See picture (6-16).

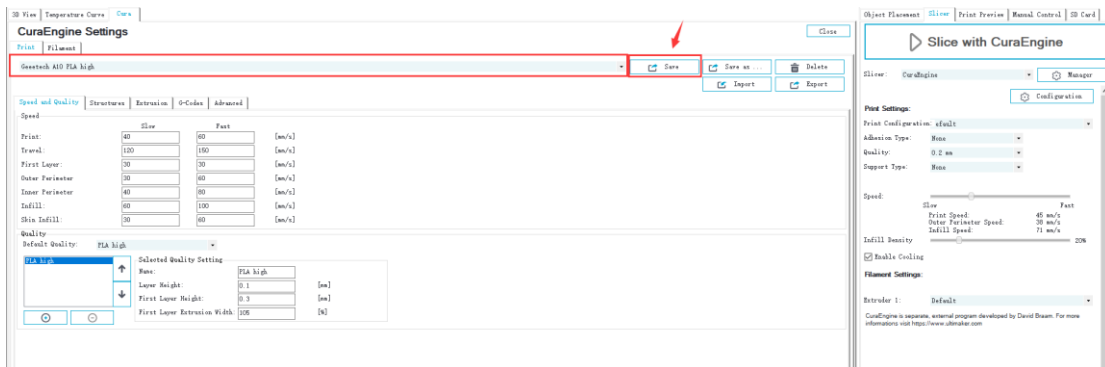

(Picture 6-16)

Click “Filament>Import”, see picture (6-17).

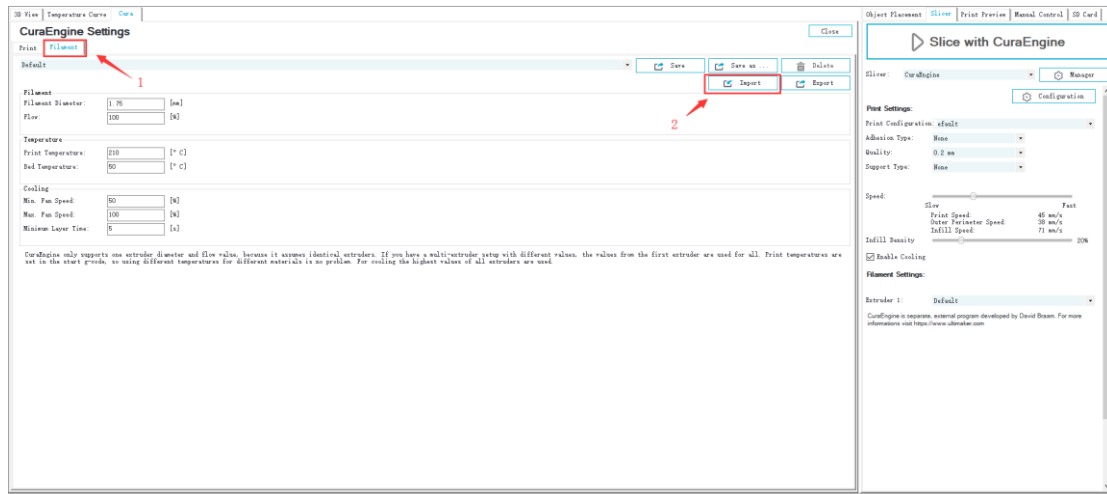

It pops up dialog as below (Picture 6-18); choose “Geheetech A10 PLA high fi.rcf”.

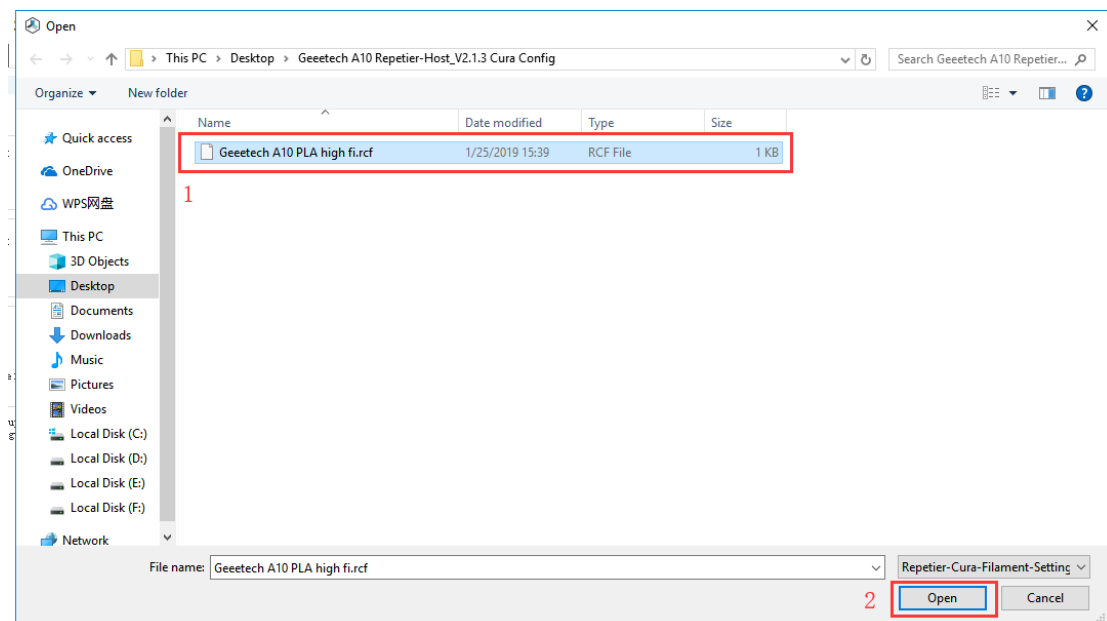

(Picture 6-18)

Now, the configuration file is imported. Click “Save”. See picture (6-19).

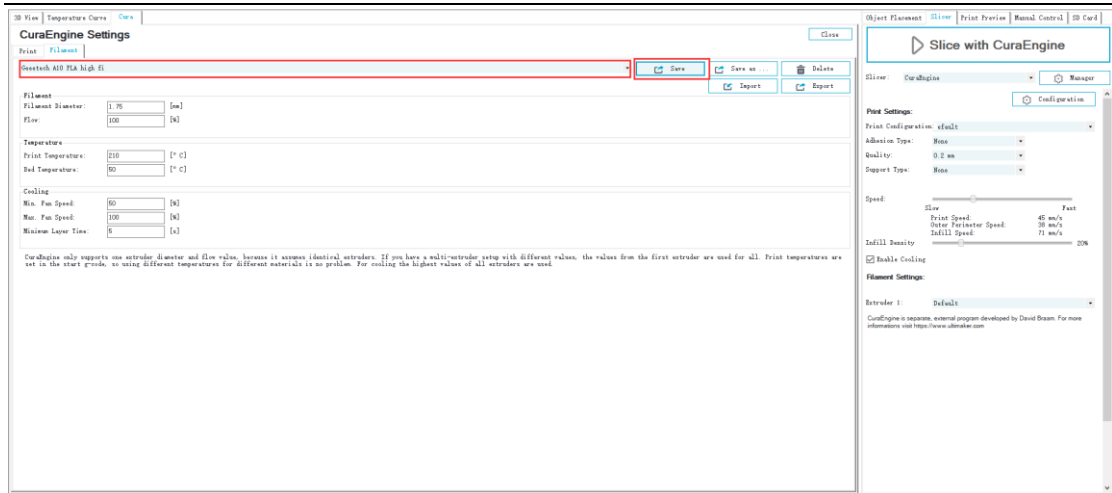

(Picture 6-19)

Choose “Geeetech A10 PLA high” as print configuration and “Geeetech A10 PLA high fi” as printing material setting. Details see picture (6-20) below.

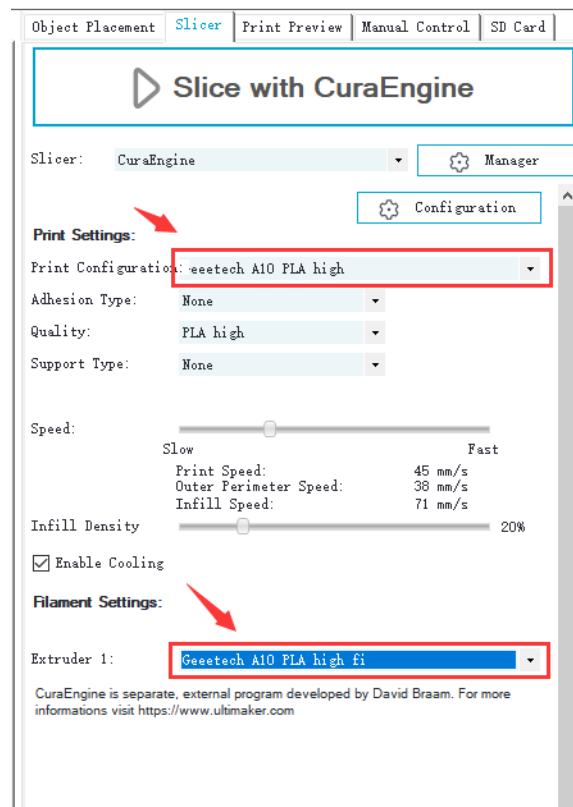

(Picture 6-20)

Now parameters setting are finished.

### 6.3 USB printing

You can start USB printing when the parameters setting are finished.

The model file format is .stl for 3D printer. You can download free models from websites such as [thingiverse](http://thingiverse.com). You can also design your own model.

1) Load the printing model

Open the Repetier-Host and click “load”. Choose a file and open it. See picture (6-21, 6-22).

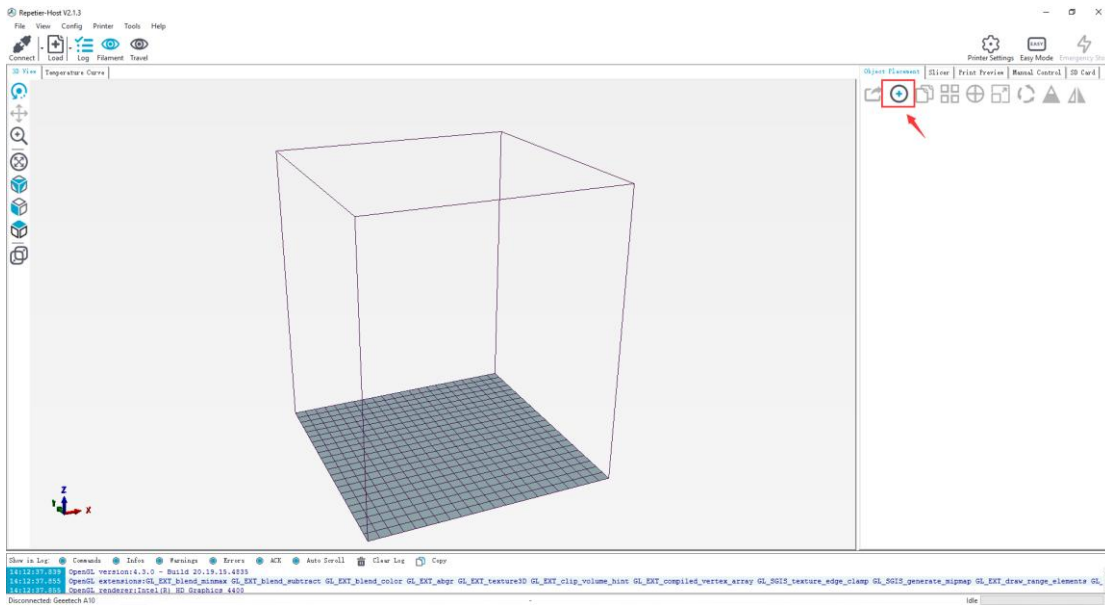

(Picture 6-21)

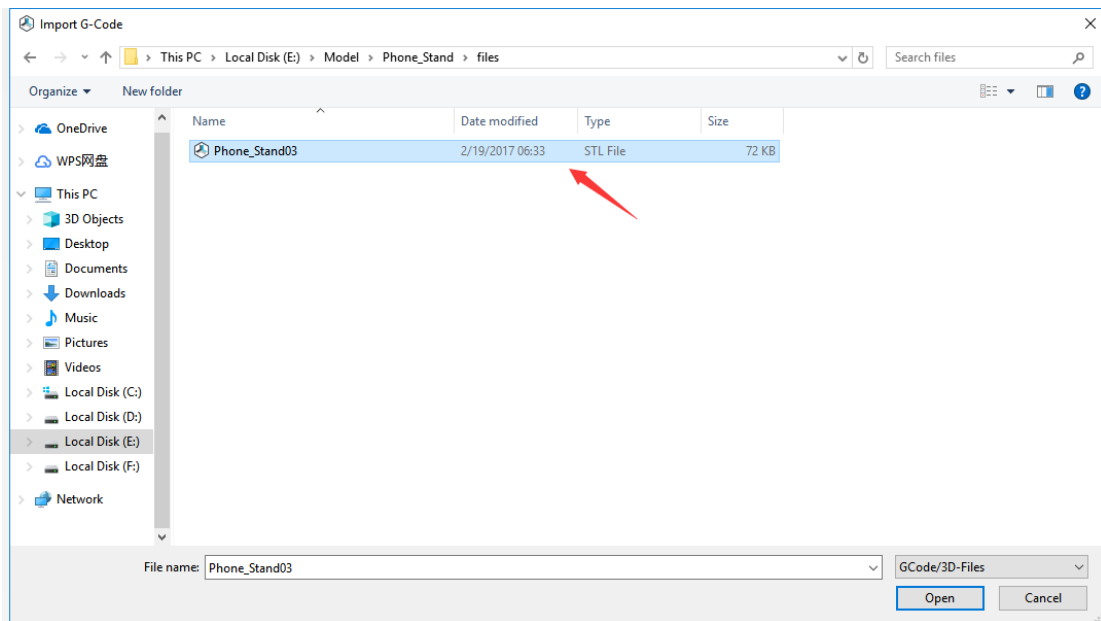

(Picture 6-22)

When it is loaded, you can use the buttons as picture below (picture 6-23) to zoom in, zoom out or rotate the model.

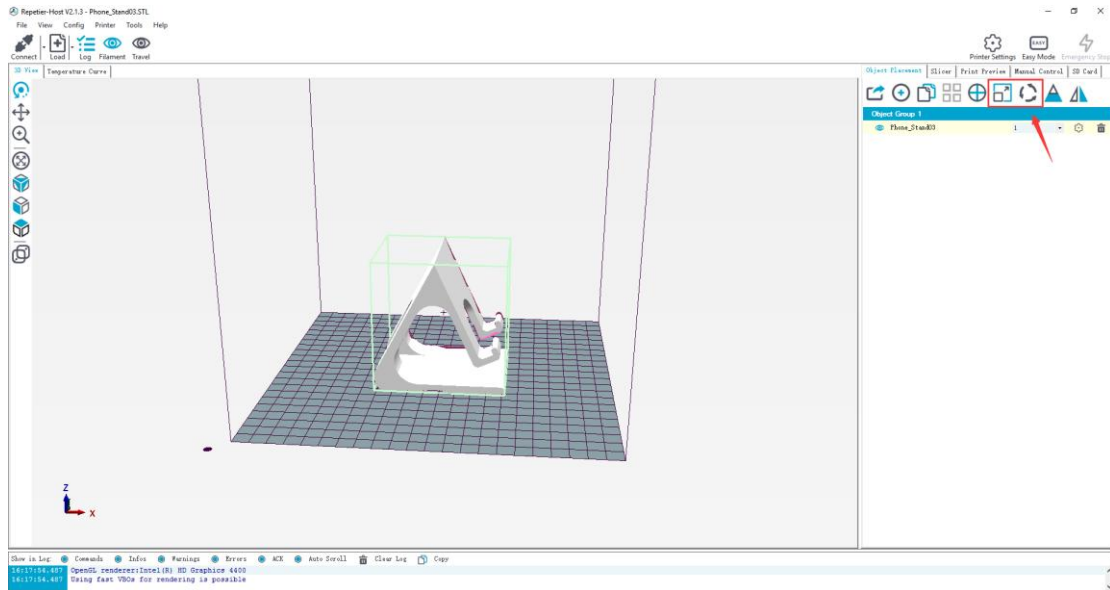

(Picture 6-23)

Adjust the direction of the model to let the flat part of the model to touch the hot bed. See picture below (6-24):

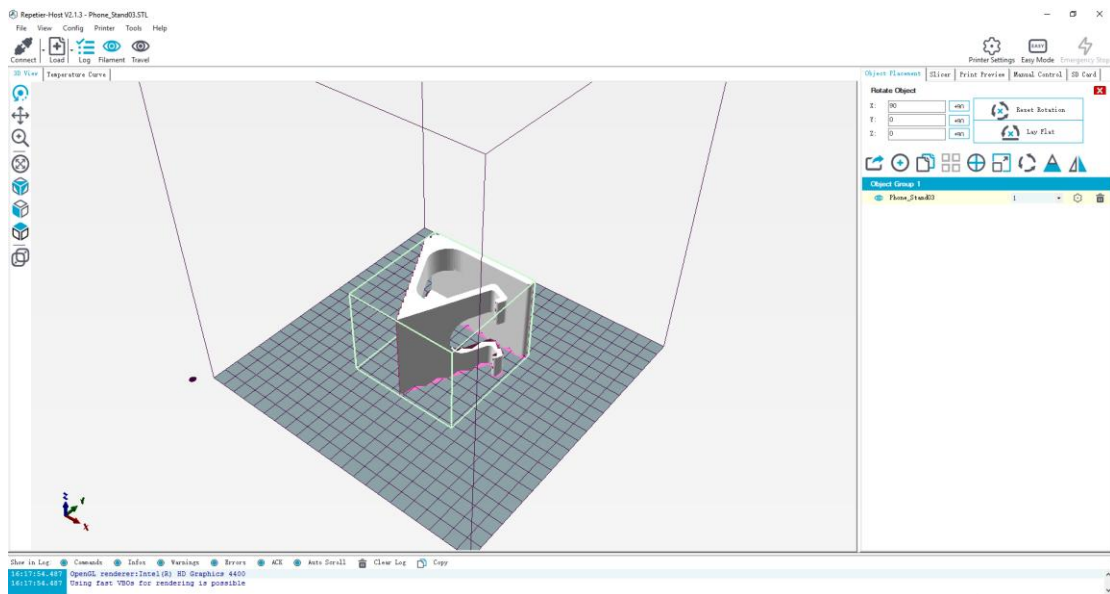

(Picture 6-24)

**Note:** If the model loaded is too big and beyond the printing platform, you need to zoom out the model. You can choose the X/Y/Z together, see picture (6-25):

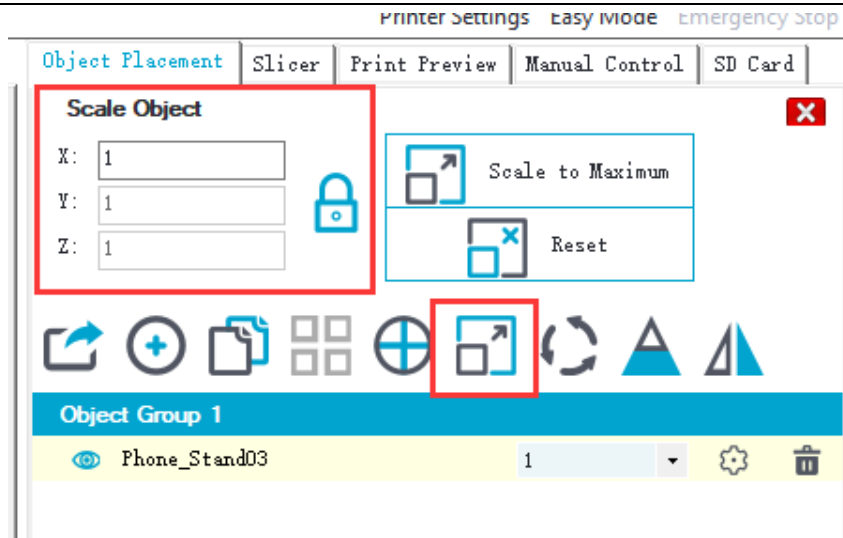

(Picture 6-25)

Or zoom in/out them separately, see picture (6-26).

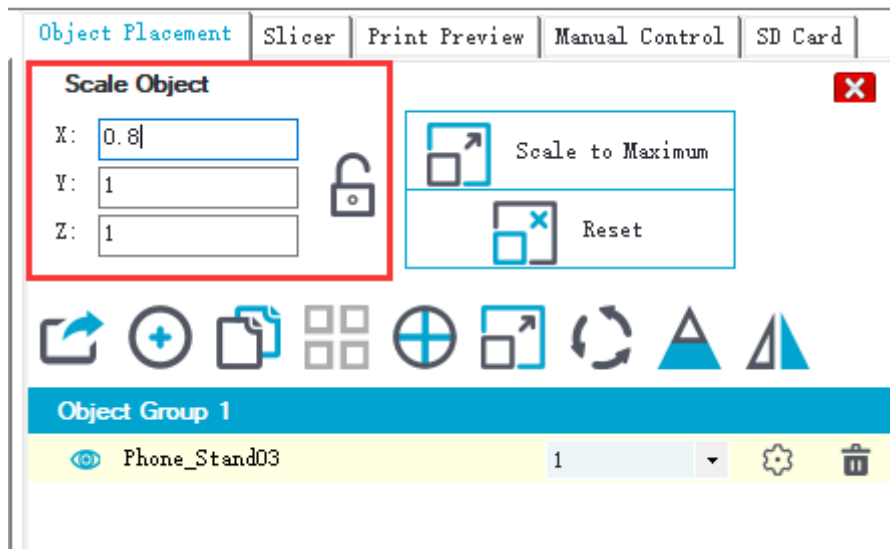

(Picture 6-26)

## 2) Model slicing

When the size and direction of the model are set, choose the imported slicing parameters, and click "Slice with CuraEngine". See picture (6-27, 6-28).

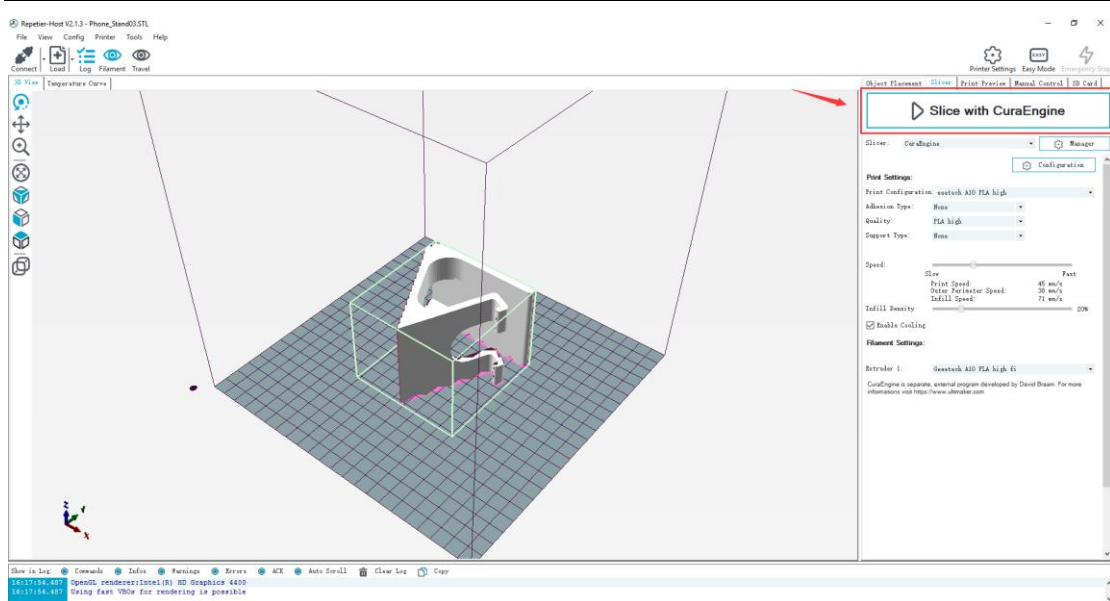

(Picture 6-27)

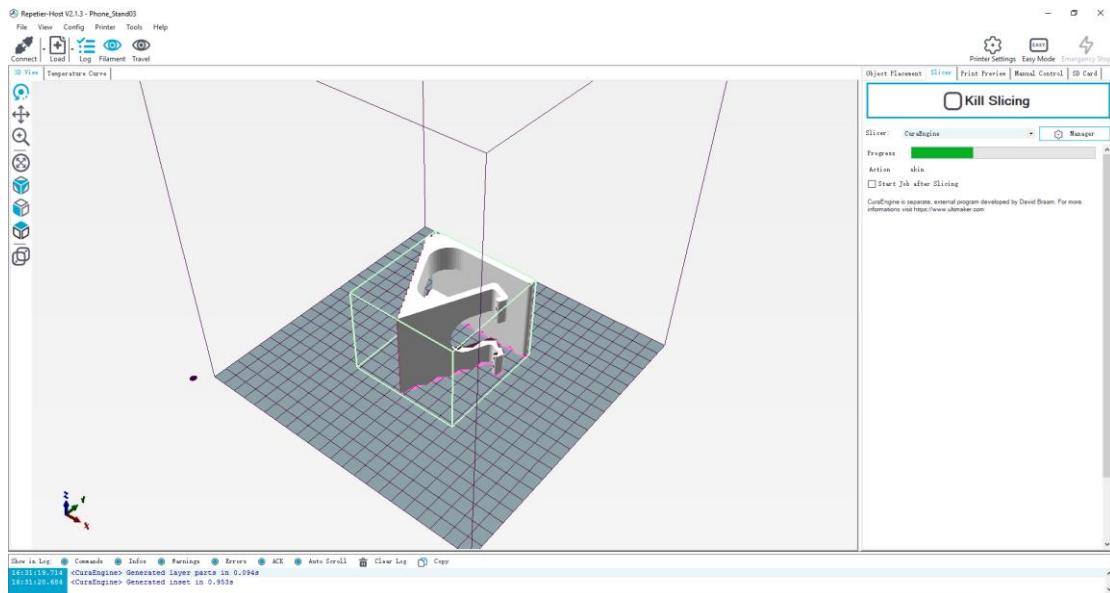

(Picture 6-28)

You can find the model information such as estimated print time, the amount of filament needed, etc. Click “Print” to start USB printing. Refer to picture (6-29).

The printer will heat to the target temp and then start printing. Under high temperature, the filament will flow out of the nozzle, which is normal. You can use tweezers to clean up the residual material of the nozzle.

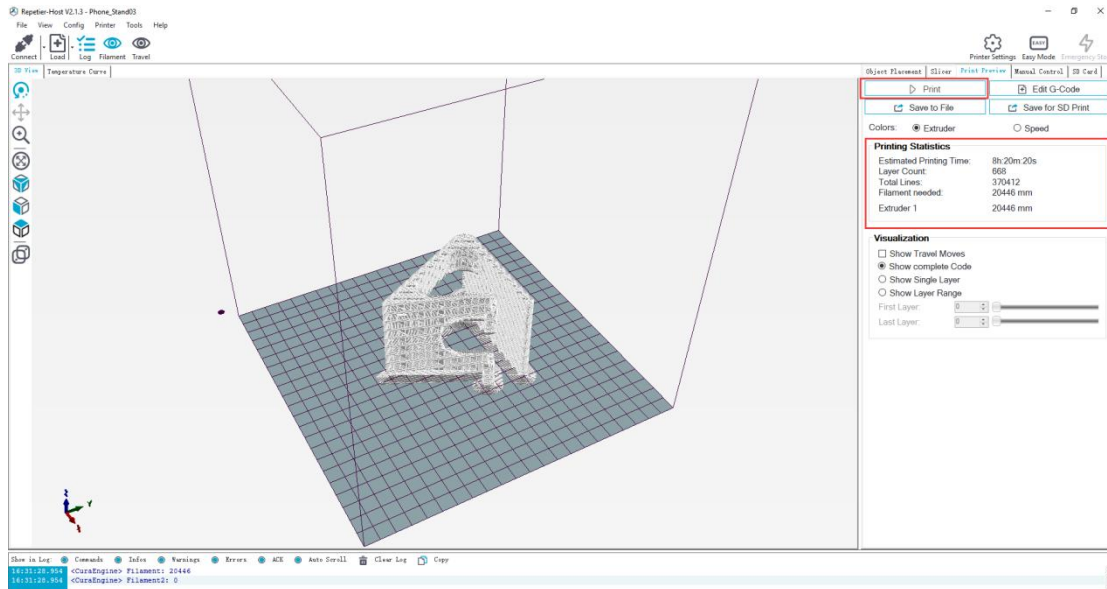

(Picture 6-29)

## 6.4 SD card printing

When all parameters are set, click “Save for SD print”. It will pop up a dialog as picture below (See picture 6-30) and then click the save button to generate a .gcode file. Copy the gcode file to the SD card.

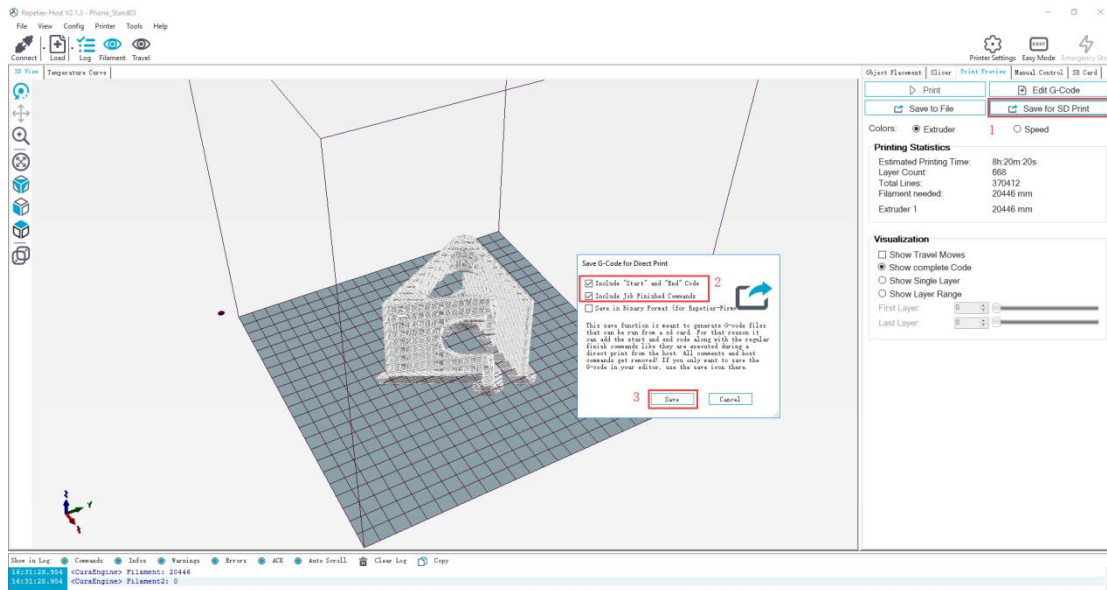

(Picture 6-30)

Insert the SD card into the slot which is on the right side of the LCD screen. Press the knob to enter the main menu and choose “Print from SD”. See picture (6-31)



(Picture 6-31)

Choose the corresponding gcode file to start printing.

**Note:**

- 1) The printer can only read gcode file and the file name should be English letters, a space, an underscore or their combination.
- 2) The Gcode file cannot be placed in any folder of the SD card, otherwise it cannot be read.

## 7 Function introduction

### 7.1 Break-resuming capability

A10 has the break-resuming capability. When the power recovery, it will pop up a dialog to ask if continuing the unfinished print caused by power outage, choose “Resume print”. See picture (7-1).



(Picture 7-1)

When it reaches the target temperature, the X and Y axes will auto home. The extruder will extrude the residue in the nozzle. Use a tweezers to clean the nozzle before starting printing again.

**Note:**

- 1) When power outage, remove the nozzle from the printing model in case the resting filament in the nozzle will ruin the model.
- 2) Be sure to clean the residue in the nozzle before re-starting the print or it would be affecting the quality of the print.

### 7.2 Reset button

The reset button is below the knob. When the printer works abnormally, press the reset button to reset the printer to avoid any damage. See picture (7-2).

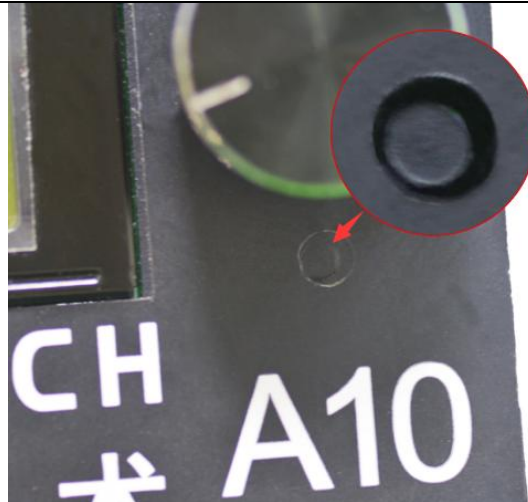

(Picture 7-2)

### 7.3 Filament run-out sensor (Optional)

Before using this function, please check whether it is turned on or not. Choose "Control">"Filament">"Runout sensors" and make sure it shows "ON". See pictures (7-3, 7-4).



(Picture 7-3)



(Picture 7-4)

- 1) It will pop up the notification "Err: No Filament" when the filament is run out during printing and the printer will stop working. See picture (7-5).



(Picture 7-5)

- 2) Press the extruder handle, remove the remaining filament before loading the new filament.
- 3) When the filament is loaded, use a tweezers to clean the nozzle. Press the knob to enter the main menu, and choose "Resume print" to re-start the printing. See picture (7-6).



(Picture 7-6)

## 7.4 3D touch for auto bed leveling (Optional)

This printer supports auto bed leveling. Refer to the link below to know how to install the 3d touch sensor.

<https://www.youtube.com/watch?v=RtsZDbR2po&t=66s>

Visit our official forum.

<http://www.geeetech.com/forum/>

## 8 Parameters

### 1) Printing parameters

Printing technology: FDM

Printing volume: 220\*220\*260mm<sup>3</sup>

Printing accuracy: 0.1~0.2mm

Positioning precision: X/Y: 0.011mm    Z: 0.0025mm

Printing speed: 80mm/s

Nozzle quantity: 1 nozzle

Nozzle diameter: 0.4mm

Filament diameter: 1.75mm

Filament: ABS/PLA/wood-polymer/PVA/HIPS/PETG, etc.

### 2) Temperature parameters

Environment temperature: 10°C-40°C

Nozzle temperature: Max temp 250°C

Hotbed temperature: Max temp 110°C

### 3) Software parameters

Operating system: Windows/Mac/Linux

Slicing software: Repetier-Host, EasyPrint 3D, Cura, Simplify3D, Slic3r, etc.

File format: .STL/.Gcode

4) Electrical parameters

Power input: 115V/230V

Power output: DC24V, 360W

Connectivity: SD card, USB

LCD screen: LCD2004

5) Mechanical parameters

Printer size: 478x413x485 mm<sup>3</sup>

Package size: 488x235x465 mm<sup>3</sup>

Net weight: 7.6kg

Gross weight: 8.84kg

## 9 Contact

Official website: <https://www.geeetech.com/>.

Facebook Group:



Email us for technical support: [https://www.geeetech.com/contact\\_us.html](https://www.geeetech.com/contact_us.html)

## **10 FAQ (Frequently Asked Questions)**

### **10.1 Abnormal extrusion**

- 1) The filament is tangled
- 2) The nozzle temp is too low to reach the melting temperature required.
- 3) There is carbonized residue inside the nozzle. Please replace it with the spare nozzle
- 4) Insufficient heat dissipation of radiator of the extruder head causes the filament in the tube to melt in advance and the extrusion strength is insufficient. Please check whether the cooling fan works normally.
- 5) The printing speed is so fast that the extruding speed can't match it. Please reduce the printing speed.

### **10.2 The gear of the extruder skips and makes an abnormal noise**

- 1) The nozzle is clogged; please refer to **10.1 abnormal extrusion**.
- 2) Check whether the friction force between the extruder gear and the filament is enough. Please clean the residue.
- 3) Check whether the voltage of the drive of the extruder is normal, and try to increase it by 0.1v until it works normally.

### **10.3 First layer abnormal**

- 1) Non-stick: a. the nozzle is too far from the hot bed. Please re-level the bed; b. try to stick masking paper and solid glue on the surface of the hot bed.
- 2) Not extruding and the bed scratched: a. the nozzle is too close from the hot bed. Please re-level the bed; b. check if the nozzle extrusion normal.

### **10.4 Layer shift**

- 1) The printing speed is too fast. Please slow it down.
- 2) The belt of X or Y axis is too loose. Please tighten it.
- 3) The X or Y axis synchronization wheel is not fixed firmly. Please adjust the meter screws.
- 4) The voltage of the drive of X/Y axis is too low.

## 10.5 Print stopped

- 1) USB printing: the signal is interfered. Please copy the model to SD card and print via SD card.
- 2) SD card printing: the gcode file in the SD card is abnormal, please slice again.
- 3) The quality of the SD card is poor. Please try another SD card.
- 4) The power supply voltage in the area is not stable; please print after the voltage is stable.

Visit our official forum for more information:

<http://www.geeetech.com/forum/viewtopic.php?f=98&t=61864>

## 11 Declaration

### 11.1 Terms

Please be advised of the following terms (the “Terms”) regarding this User Manual (this “Manual”):

All information in this Manual is subject to change at any time without notice and is provided for convenience purposes only. Geeetech reserves the right to modify or revise this Manual in its sole discretion and at any time. You agree to be bound by any modifications and/or revisions. Contact the Geeetech Support Team for up-to-date information.

### 11.2 Disclaimers

Neither Geeetech nor any of our affiliates warrants the accuracy or completeness of the information, products, or services provided by or through this Manual, which are provided “as is” and without any express or implied warranties of any kind, including warranties of merchantability, fitness for a particular purpose, or non-infringement of intellectual property. To the fullest extent permissible by the applicable law, we hereby disclaim all liability for product defect or failure or for claims that are due to normal wear, product misuse or abuse, product modification, improper product selection, noncompliance with any codes, or misappropriation. To the fullest extent permissible by the applicable law, we hereby disclaim any and all responsibility, risk, liability, and damages arising out of death or personal injury resulting from assembly or operation of our products. Geeetech assumes no responsibility, nor will be liable, for any damages to, or any viruses or malware that may infect your computer, telecommunication equipment, or other property caused by or arising from your downloading of any information or materials related to Geeetech products.



Shenzhen Getech Technology Co.,Ltd

[www.geeetech.com](http://www.geeetech.com)