

## Assembly Instructions of Geetech Aluminium Prusa I3

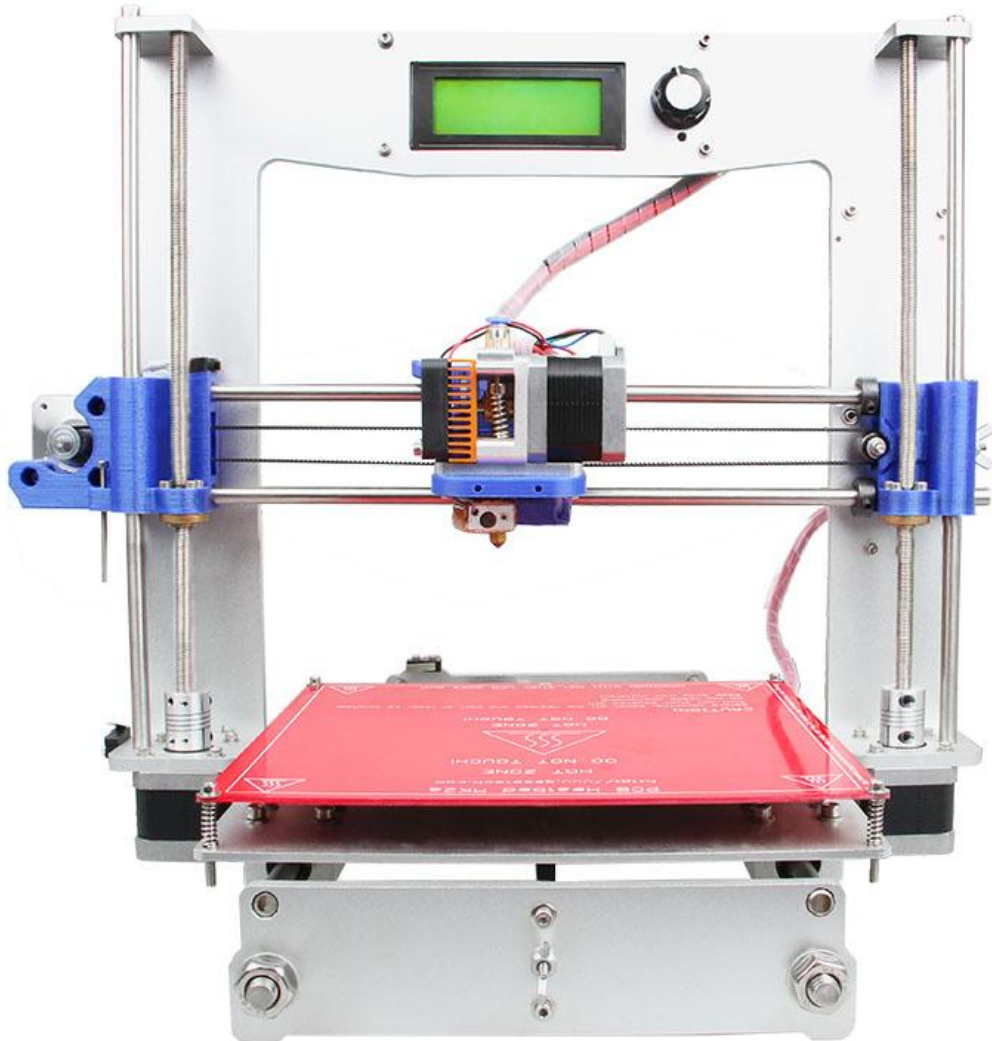

CONTENT

Assembly Instructions of Geeetech Aluminium Prusa I3 .....	1
CONTENT .....	2
Safety Instructions .....	3
Preparation .....	4
1. Unfold the box and check the package.....	5
2. Assemble Y axis .....	5
2.1 Assemble the 2 threaded rods. ....	5
2.2 Attach the front and rear side support plates of the rods.....	6
2.3 Assemble the Y idler .....	7
2.4. Mount the Y motor .....	9
3. Build the printing platform .....	10
4. Assemble Y smooth rods.....	11
5. Mount the Y-axis belt .....	11
6. Assemble the Z-axis stepper motor, bottom mount and couplings.....	12
7. Assemble Y - Z axis .....	13
8. Assemble the X axis (the horizontal axis).....	14
8.1 Assemble the X-Axis left end .....	14
8.2 Assemble the X-Axis right end .....	16
8.3 Assemble the extruder carriage. ....	16
9. Assemble the X-axis and Z-axis together.....	18
10. Assemble the X belt driving wheel .....	20
11. Mount the LCD panel.....	22
12. Mount the fan .....	23
13. Mount the board on the left side panel of the printer .....	24
14. Attach he heated bed. ....	25
15. Mount the endstops of Y and Z axis.....	26
16. Wiring .....	27
17. Arrange the wires and tidy them up with the coil. ....	28

## **Safety Instructions**

Building the printer will require a certain amount of physical dexterity, common sense and a thorough understanding of what you are doing. We have provided this detailed instruction to help you assemble it easily.

However ultimately we cannot be responsible for your health and safety whilst building or operating the printer, with that in mind be sure you are confident with what you are doing prior to commencing with building or buying. Read the entire manual to enable you to make an informed decision.

Building and operating involves electricity, so all necessary precautions should be taken and adhered to, the printer runs on 12V supplied by a certified power supply, so you shouldn't ever have to get involved with anything over 12V but bear in mind there can still be high currents involved and even at 12V they shouldn't be taken lightly.

High temperatures are involved with 3D Printing, the Extrusion nozzle of the hot end can run about 230 °C, the heated bed runs 110 °C and the molten plastic extruded will initially be at around 200 °C, so special care and attention should be made when handling these parts of the printer during operation.

We wouldn't recommend leaving your printer running unattended, or at least until you are confident to do so. We cannot be held responsible for any loss, damage, threat, hurt or other negligent result from either building or using the printer.

### **Preparation**

1. Unpack the kit and check if all parts are in the box and check the condition of each part, there might be some damage during shipping. To help you with this, there is BOM in the box and each bag was labeled with part number.
2. Contact our customer service immediately by email or through the website if you find any missing or damaged parts. And on the bottom of the BOM, there is a signature of reviewer, please take a picture of it and attach the picture in your mail.
3. Read through each chapter of these instructions to gain an over-all idea of what is involved and how long it might take, before starting on the work described.
4. Before you start, you can put all the part in order to save your time especially those screws and nuts. Do not mix them up.
5. Ensure you have the necessary skills to carry out the work, or enlist the help of someone who does.
6. Work on a big firm table or bench in a clean dry well-lit area.
7. This kit contains tiny parts; please keep them away from kids under 3.
8. Ask for help if you run into any problems - our contact details are on the website and we will always do our best to resolve any problems encountered.

## 1. Unfold the box and check the package

Unfold the package and take all the parts out to check the condition of the items. As you can see, all the parts are packed very carefully.





### Tips:

1. Before assembly, you are advised to put all the parts, especially the screws and nuts in order, which will save you a lot of time looking for the required parts.
2. The part ID is corresponding to the number labeled on the bag of every part. Some parts may not have label, you can refer to the pictures on the package list.

## 2. Assemble Y axis

### 2.1 Assemble the 2 threaded rods.

#### [Video](#)

Required parts	Required number	Part ID	Pic
Y threaded rod	2	NO.5	
connecting plate	2	NO.A12	
Spring washer	6	NO.10	
M10 washer	8	NO.9	
M10 nut	8	NO.13	

Thread the nuts and washers into the two M10 threaded rods separately. The orders should be:

- 1) Thread the Y plate connecting plate in the middle.



2) Thread the M10 washer > spring washer >M10 nut > M10 nut > M10 washer on the left

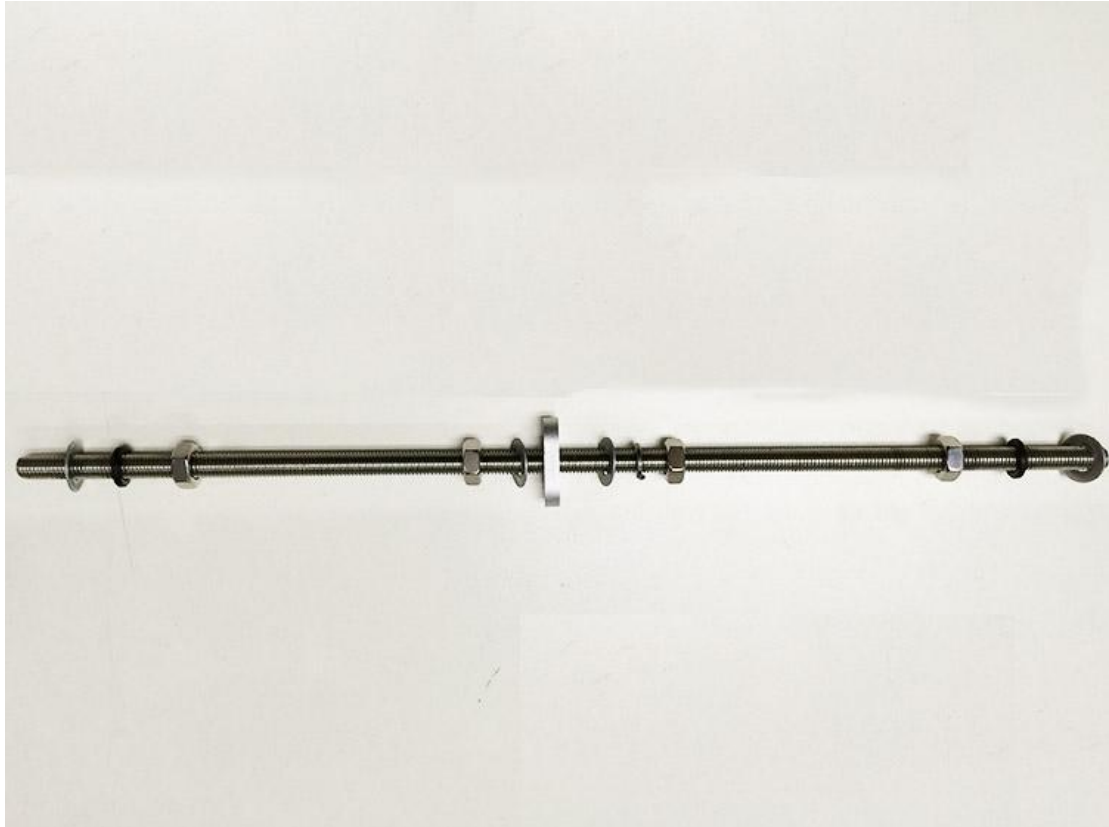

3) Thread theM10 washer < spring washer < M10 nut < M10 nut< spring washer < M10 washer on the right



**2.2 Attach the front and rear side support plates of the rods.**

[Video](#)

<b>Required parts</b>	<b>Required number</b>	<b>Part ID</b>	<b>Pic</b>
Front Side Support	1	NO. A2	
Rear Side Support	1	NO.A3	





M10 washer	4	NO.12	
M10 nut	4	NO.13	









Slide assembled threaded rods into the side support plates. Screw up the rods and plates with 4 M10 nuts and M10 washers.

*\* Tips:the Y-axis must be a rectangle, that is the rods on both side should be parallel, so is the front and rear plate. Otherwise it will cause obstruction for the belt later.*

### 2.3 Assemble the Y idler

[Video](#)

Required parts	Required number	Part ID	Pic
624ZZ Ball bearing	2	NO.34	
bearing holder	1	NO.38	
M4 x25 screw	1	NO.28	
M4 lock nut	1	NO.12	
Guide Block A	1	NO.A10	

Guide Block B	1	NO.A11	
M3 x 25screw	3	NO.22	
M4x25 screw	1	NO.28	
M3 wing nut	1	NO.15	
M3 washer	3	NO.7	
M3 nut	2	NO.11	
M4 washer	2	NO.8	
M4 nut	1	NO.12	

Step1. Amount guide block A and B onto the front support plate together, screw up it with 2 M3x25 screws, M3washers and M3 nuts.

**Note: the guide block B is close to front support plate.**

Step2. Thread a M3 x25screw and M3washer through the bearing holder.

Step3. Put a M4 x25screw and M4wsaher through the holes with the two 624ZZ bearings in between. Lock the other end with a M4 lock nut. You may need a spanner to tighten locknut.







Step4. Mount the assembled bearing holder through the guide blocks onto the front support plates. And screw it with a wing nut.

**\*Please leave enough room for the belt between the ball bearing and the screw.**



## 2.4. Mount the Y motor

### [Video](#)

Required parts	Required number	Part ID	Pic
Y motor fixed plate	1	NO. A9	
Stepper motor	1	NO.57	
pulley	1	NO.36	
M3 x 10screw	3	NO.19	
M3x16screw	2	NO.20	
M3 washer	5	NO.7	







Step1. Mount the pulley on the motor shaft, one of the screws should be screwed on the cross section of the shaft. Screw it up tightly.

Step2. Insert the motor block into the slot; you may need to use a little strength to do this. Then screw the motor on the Y motor fix plate with 3 M3 x 10 screws and M3washers

Step3. Fix the block plate with 2 M3 x 16 screws and M3 washers.

### 3. Build the printing platform

[Video](#)

Required parts	Required number	Part ID	Pic
Y building platform	1	NO.A5	
Y belt mount	1	NO.39	
SCS8UU linear bearing	4	NO.32	
Zip tie	4	NO. 43	
M3 x 10 screw	2	NO.19	
M4x12 screw	16	NO.26	



M4 washer	18	NO.8	
-----------	----	------	---

Step1. Mount the belt mount on the bottom side of the platform with 2 M3 x 10 screws and M3washers.

Step2. Mount the 4 SCS8UU linear bearing on the platform with 16 M4x12 screws and M4 washers on the same side with the belt-mount.

#### 4. Assemble Y smooth rods

[Video](#)



Required parts	Required number	Part ID	Pic
Y smooth rod	2	NO.3	
Lock screw M3x4 mm	4	NO.29	

Thread two smooth rods through: front side support [A2]> linear bearings > rear side support [A3] respectively. And screw it with 4 lock screws.

When threading the rod, please make sure the holes are aligned and do not force it, or you will break the balls in the bearings.

#### 5. Mount the Y-axis belt

[Video](#)

Required parts	Required number	Part ID	Pic
Timing belt	1	NO.37	
M3 x 8 screw	2	NO.18	
M3 washer	2	NO.7	

Step1. Punch a hole on one end of the belt (the hole can be as the diameter of the M3 screw, leave enough margin )

Step2. Fix the belt on one side of the belt -mount with a M3 x 8 screw and washer.

Step3. Thread the belt around the pulley on the motor and the Y idler.

Step4. Punch a hole on the other end of the belt and fix it on the belt -mount with a M3 x 8 screw and M3 washer.

**\*Tips:**







1. Before you drill your second hole, make sure to pull belt tightly to make sure to find proper placement of hole for a tight belt, if it is too loose, it will hinder the move of the print platform.

2. Loosen the Y idler wing nut when tightening belt onto the Y belt mount, in order to make securing the belt to the block easier. Be sure to tighten wing nut fully once done.

**6. Assemble the Z-axis stepper motor, bottom mount and couplings**

[Video](#)

Required parts	Required	Part ID	Pic
----------------	----------	---------	-----

	<b>number</b>		
X-Z frame	<b>1</b>	NO.A1	
Z Motor fixed plate	2	NO. A6	
Stepper Motor	2	NO.57	
Coupling	2	NO.35	
M3 x 16screw	4	NO.20	
M3x10 screw	8	NO.19	
M3 washer	12	NO.7	



Step1. It would be easier to mount the motor on plates first, screw it with 8 M3x10screws and M3 washers

Step2. Thread the wires of the motors through the hole. Mount the assembled motor to the X-Z frame (A1), and screw the X-Z frame with 4 M3 x 16screws and M3washers.

Step3. Mount the coupling on the motor shaft, one of the screws should be screwed on the cross section of the shaft. Screw the small screw tightly.

**7. Assemble Y - Z axis**

[Video](#)

<b>Required parts</b>	<b>Required number</b>	<b>Part ID</b>	<b>Pic</b>
M3 x 16 screw	4	NO.20	
M3 washer	4	NO.7	



Step1. Held upright the X-Z frame on the threaded rods (Right after the Y connecting plate)









Step2. Screw up the main frame to the Y connecting plate with 4 M3 x16 screws and M3 washers.

**8. Assemble the X axis (the horizontal axis)**

[Video](#)

**8.1 Assemble the X-Axis left end**

<b>Required parts</b>	<b>Required number</b>	<b>Part ID</b>	<b>Pic</b>
X-axis left end	1	NO.P1	
Brass nut	1	NO.16	
M3 x 16 screw	4	NO. 20	

Stepper motor	1	NO.57	
Pulley	1	NO.36	
M3 x 10screw	3	NO.19	
End stop	1	NO.45	
M2.5 X 16 screw	2	NO.17	
M3 x50 screw	1	NO.25	
M3wsaher	7	NO.7	
M2.5 washer	2	NO.6	

Step1. Mount a brass nut under left end with 4 M3 x 16 screws and M3washers.

Step2.Mount end stop of X-axis.

1).Mount the X end stop on the top of X-axis left end, and screw it with 2M2.5x16 screws and M2.5 washers.

2). Fix the M3x 50 screw on left end. (This is for the Y end stop).





Step3. Mount the X-axis motor.

1) Mount the pulley on the motor shaft, one of the screws should be screwed on the cross section of the shaft. Screw it tightly.

2) Mount stepper motor on the left end, and screw it with 3M3x10screws and washers.

**\*Please pay attention to the mount direction of the pulley, which is opposite to that of the Y-axis.**

### 8.2 Assemble the X-Axis right end

Required parts	Required number	Part ID	Pic
X-axis right end	1	NO.P2	
M3 x 16 screw	4	NO. 20	
M3 washer	4	NO.7	
Brass nut	1	NO.16	

Step1. Mount a brass nut under the X-axis right end with 4 M3 x 16 screws and M3 washers.



### 8.3 Assemble the extruder carriage.

#### [Video](#)

Step1. Mount the X-axis belt bracket on the smooth rods.

Required parts	Required number	Part ID	Pic
----------------	-----------------	---------	-----







belt bracket	1	NO.P4	
Zip tie	4	NO.43	
LM8UU linear bearing	2	NO.33	

- 1) Insert the linear bearings into the slot of the bracket.
- 2) Thread the zip-tie through the belt bracket. Tie them up with zip ties.

*\*The stretch-out part is towards the Left X-axis end.*



Step2. Mount the extruder holder to the belt bracket.

Required parts	Required number	Part ID	Pic
Extruder holder	1	NO.P3	
M4 x 12screw	2	NO.26	
M4 nut	2	NO.12	
M4washer	2	NO.8	

- 1). Put the 2 M4 nut into the hole on the Extruder holder.
- 2). Screw up the belt bracket and the extruder holder with 2 M4 x 12 screws and M4washers.

\*Note: In the video, the P3 is a 3D printed part, for better printing effect, we have upgraded this part as a metal part, so there is a bit difference from the video. Detailed information is in accordance with the final product.

Step3.Mount the extruder on the holder

Required parts	Required number	Part ID	Pic
MK8 extruder	1	NO.55	
M4 x 6 screw	2	NO.27	
M4 washer	2	NO.8	

Mount the assembled extruder on the extruder holder. Use 2 M4 x 6 screws and M4washers to fix it.

### 9. Assemble the X-axis and Z-axis together

#### [Video](#)

Step1. Assemble the X-axis







So far, we have finished the three main part of the X axis, now we can assemble them together.

Required parts	Required number	Part ID	Pic
X smooth rod	2	NO.2	

Screw	2	NO.30	
Lock ring			

Thread the left end>extruder part >the screwing >right end onto the smooth rods in turn.

Step1. Assemble the Z-axis

Required parts	Required number	Part ID	Pic
Z threaded rod	2	NO.4	
Z smooth rod	2	NO.1	
M3x4 mm Lock screw	2	NO.29	
Z Top Support plate	1	NO.A7	
M3 x 16 screw	4	NO. 20	
M3wsaher	4	NO.7	







- 1) .Thread two threaded rods through two the brass nuts, keep both end aligned.
- 2). Connect the bottom end of the threaded rods to the couplings respectively. If the distance between the two threaded rods is different from that of the two couplings, you need to adjust one end of the X axis to make sure the threaded rods are vertical.
- 3). Thread the smooth rods into the bearings on the two ends. Be gentle, please.
- 4). Mount the two Z top support plates to the X-Z frame. Screw up it with 4 M3x16 screws and M3 washers.
- 5). screw up the couplings very tightly

6). fix the locking rings on the X axis smooth rod.

7). screw up the Z smooth rod at the bottom with 2 M3x4Lock screws.

### 10. Assemble the X belt driving wheel

[Video](#)

Required parts	Required number	Part ID	Pic
624ZZ Ball bearing	2	NO.34	
Driving wheel holder	1	NO. 38	
M3 x40 screw	1	NO.24	
M4 x25 screw	1	NO.28	
M4 locknut	1	NO.14	
Wing nut	1	NO.15	
M4wsaher	1	NO.8	



#### Step2. Assemble the X-Axis Idler

- 1) Thread a M3 x40screw and M3washer through the driving wheel holder.
- 2) Thread a M4 x 25screw and M4waher through the holder with the 624ZZ bearings in between. Lockthe other end with a M4 nut.

Step3. Mount the assembled bearing holder on the right end. And screw it with a

wing nut.

**11. Mount the X-axis belt.**

Required parts	Required number	Part ID	Pic
Timing Belt	1	NO.37	
Zip tie	2	NO.43	

Step1. Thread the belt around pulley on the motor end.

Step2. Insert one end of the belt in the slot. Tie it up with a zip tie.

Step2. Another end of the belt should be threaded through the belt driving wheel on the right end of the X-axis.







Step3. Insert another end of the belt into the slot. You may need to use the tweezers to help you insert the belt.

**\*Pay attention to the tooth mesh of the belt and that on the bracket. Tie up both ends tightly.**

**\* Do not rush to cut the belt until you are sure of the belt length.**

11. Mount the LCD panel

[Video](#)





Required parts	Required number	Part ID	Pic
LCD 2004	1	NO.58	
Spacer	4	NO.40	
knob	1	NO.59	
M3washer	4	NO.7	
M3 x 20 screw	4	NO.21	
M3 nut	4	NO.7	

Mount the LCD into the top of main frame from back to front; screw it up with 4M3x16 screws, M3 washers and M3 nuts.

**\*Note: Four spacers should between LCD and frame.**

**12. Mount the fan**

[Video](#)





Required parts	Required number	Part ID	Pic
Fan	1	NO.49	
M3 x 25screw	2	NO.22	
Fan mount	1	NO.A4	
M3washer	4	NO.7	
M3 x 16screw	2	NO.20	

Fix the fan on the fan mount with 2 M3 x 25 screws and M3 washers. Mount the fixed block on the main frame with 2 M3x16 screws and M3 washers.

**\*Mind the direction of the wires.**

**13. Mount the board on the left side panel of the printer**

[Video](#)

Required parts	Required number	Part ID	Pic
Control board	1	NO.56	
M3 x 20screw	4	NO.21	
Spacer	4	NO.40	
M3washer	4	NO.7	
M3 nut	4	NO.11	

Mount control board onto the back of X-Z frame, and screw up it with M3x20screws, M3washers and M3 nuts.

**\*Attention:**









The four A4988 stepper motor driver board is plugged on the board before shipping.

The four spacers should be between X-Z frame and control board.



14. Attach he heated bed.

[Video](#)

Required parts	Required number	Part ID	Pic
Heat bed	1	NO.48	
Borosilicate glass	1	NO.44	
Heating wire	2	NO.47	
Thermometry wire	2	NO.46	
Spring	4	NO.31	
M3 washer	4	NO.7	
M3 x30 screw	4	NO.23	
clamp	4	NO.41	

Mount the heat bed on the platform with 4 M3 x30 screws and wing nuts with springs in between. Clamp the heat bed and the glass sheet.

**\*Note**



The heating wire is pre-soldered on the bed and the thermometry wire is attached on the bed.

The soldered side is better to be attached downwards.

**15. Mount the endstops of Y and Z axis**

[Video](#)



Step1. End stop of Y-axis

Required parts	Required number	Part ID	Pic
End stop	1	NO.45	
M2.5 x 16 screw	2	NO.17	
M2.5 washer	2	NO.6	

Mount Y-axis end stop on the rear side support. Screw it up with M2.5x16 screws and M2.5 washers.

**Note:** there is no “+” and “-” for endstop, so there is no difference for the wires.

Step2. End stop of Z-axis

Required parts	Required number	Part ID	Pic
End stop	1	NO.45	
M 2.5x 16 screw	2	NO.17	
M2.5 washer	2	NO.6	

Mount Z-axis end stop on the left Z motor block. Screw up it with M2.5x16 screws and M2.5 washers.

## 16. Wiring

Please refer to the picture

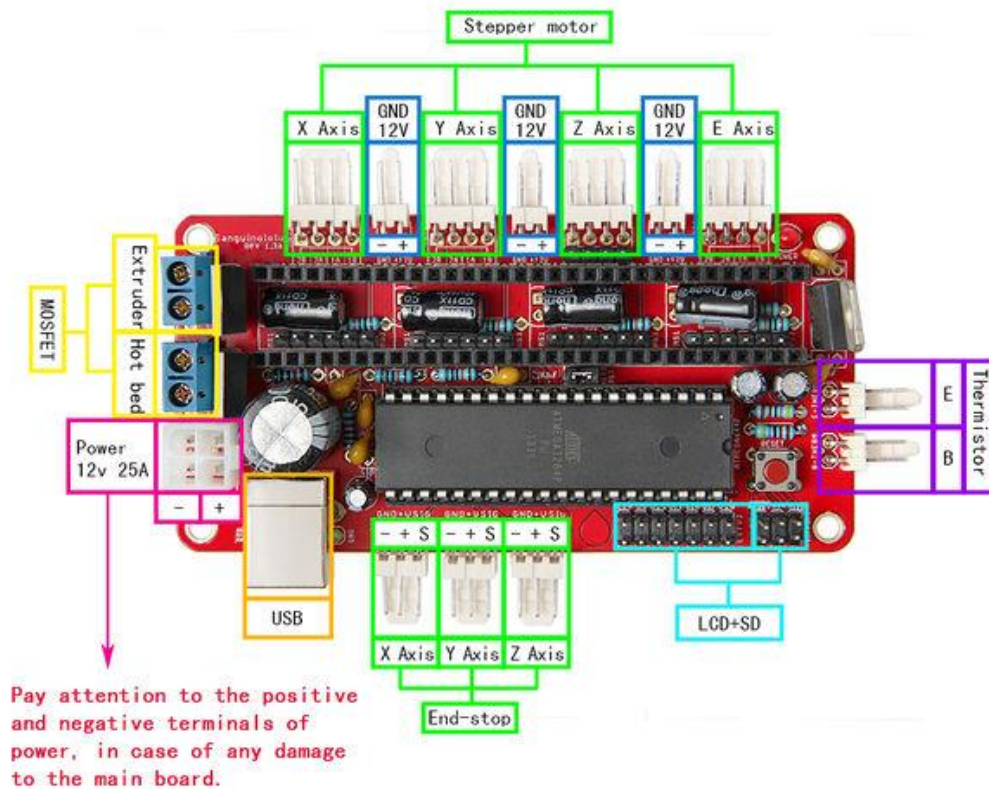

Note: there are two stepper motors for Z axis, the connector is as shown in the following picture:

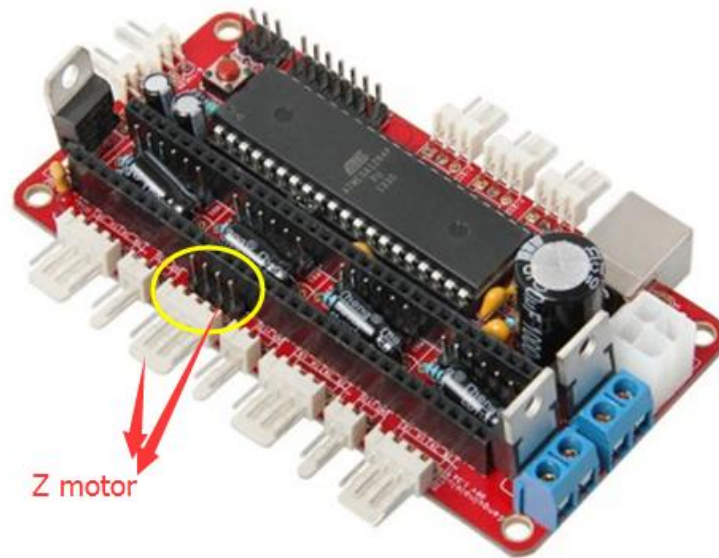

For detailed wiring instruction, please refer to the [video](#).

**17. Arrange the wires and tidy them up with the coil.**

The whole printer assembly work is already done.

Hope you enjoy the whole process.